

**XtrapulsCD1-pm  
User manual**

**PROFIBUS  
POSITIONER**



Windows® is a registered trade-mark of MICROSOFT® CORPORATION.

STEP7® is a registered trade-mark of SIEMENS®.

## WARNING !



This is a general manual describing a series of servo amplifiers having output capability suitable for driving AC brushless sinusoidal servo motors.

Instructions for storage, use after storage, commissioning as well as all technical details require the MANDATORY reading of the manual before getting the amplifiers operational.

Please see [XtrapulsCD1-pm Installation Guide](#) for the hardware installation of the amplifier (dimensions, wiring, ...).

For the PROFIBUS communication, see manual [XtrapulsCD1-pm – PROFIBUS Communication Profile](#).

**Maintenance procedures should be attempted only by highly skilled technicians having good knowledge of electronics and servo systems with variable speed (EN 60204-1 standard) and using proper test equipment.**

The conformity with the standards and the "CE" approval is only valid if the items are installed according to the recommendations of the amplifier manuals. Connections are the user's responsibility if recommendations and drawings requirements are not met.



Any contact with electrical parts, even after power down, may involve physical damage. Wait for at least 5 minutes after power down before handling the amplifiers (a residual voltage of several hundreds of volts may remain during a few minutes).



### ESD INFORMATION (ElectroStatic Discharge)

INFRANOR amplifiers are conceived to be best protected against electrostatic discharges. However, some components are particularly sensitive and may be damaged if the amplifiers are not properly stored and handled.

#### STORAGE

- The amplifiers must be stored in their original package.
- When taken out of their package, they must be stored positioned on one of their flat metal surfaces and on a dissipating or electrostatically neutral support.
- Avoid any contact between the amplifier connectors and material with electrostatic potential (plastic film, polyester, carpet...).

#### HANDLING

- If no protection equipment is available (dissipating shoes or bracelets), the amplifiers must be handled via their metal housing.
- Never get in contact with the connectors.



### ELIMINATION

In order to comply with the 2002/96/EC directive of the European Parliament and of the Council of 27 January 2003 on waste electrical and electronic equipment (WEEE), all INFRANOR devices have got a sticker symbolizing a crossed-out wheel dustbin as shown in Appendix IV of the 2002/96/EC Directive.

This symbol indicates that INFRANOR devices must be eliminated by selective disposal and not with standard waste.

All electrical industrial automatism which lifetime is coming to its end are Waste Electronic and Electrical Equipment (WEEE) according to article R543-172 of the French Environmental Code.

WEEE classification of the INFRANOR® products	Categorie 9: Monitoring and control instruments
---	---



In accordance with the Decree nr. 2012-617 of May 2<sup>nd</sup>, 2012 which specifies the provisions related to the professional EEE manufacturers' obligations, INFRANOR France is a member of RECYLUM : eco-organization **ecosystem** certified for the collection, treatment and recycling of WEEE.

In France, RECYLUM allows all professionals benefiting from a free collection and recycling solution, in observance of the regulation, the environment and health.



Information and sorting instructions regarding INFRANOR® products

	Type of waste	Waste category	Waste management
<b>Packaging</b>	Cardboard	Recyclable waste	Waste disposal centre / collection point of recyclable waste
<b>Documents</b>	Paper	Recyclable waste	Waste disposal centre / collection point of recyclable waste
<b>Mechanics</b>	Metal	Recyclable waste	Waste disposal centre / metal collection point
<b>Heatsinks</b>	Metal	Recyclable waste	Waste disposal centre / metal collection point
<b>Electronical boards and components</b>	<b>WEEE</b> (Waste Electronic and Electrical Equipment)	Dangerous industrial waste	France: <a href="http://www.ecosystem.eco/fr/sous-rubrique/solutions">http://www.ecosystem.eco/fr/sous-rubrique/solutions</a> Abroad: Country-specific regulation



Sorting instructions may vary according to regions / countries.

INFRANOR does not assume any responsibility for any physical or material damage due to improper handling or wrong descriptions of the ordered items.

Any intervention on the items, which is not specified in the manual, will immediately cancel the warranty.

Infranor reserves the right to change any information contained in this manual without notice.

# Contents

	PAGE
<b>CONTENTS.....</b>	<b>5</b>
<b>CHAPTER 1 - GENERAL DESCRIPTION .....</b>	<b>7</b>
1 - INTRODUCTION.....	7
1.1 – PROFIBUS MODE WITH SOFTWARE ADDRESSING.....	7
1.2 – PROFIBUS MODE WITH HARDWARE ADDRESSING .....	7
1.3 – STAND-ALONE MODE .....	7
2 - ARCHITECTURE OF A POSITIONER .....	8
3 - OTHER DOCUMENTS REQUIRED FOR THE COMMISSIONING .....	8
<b>CHAPTER 2 - COMMISSIONING.....</b>	<b>9</b>
1 – COMMISSIONING OVERVIEW .....	9
2 – INSTALLATION OF THE PC SOFTWARE .....	10
3 - CHECKING THE POSITIONER HARDWARE CONFIGURATION .....	10
4 - SELECTION OF THE OPERATION MODE .....	10
5 - COMMISSIONING .....	10
6 - STARTING THE "VDSETUP" SOFTWARE .....	11
7 - MOTOR ADJUSTMENT .....	11
7.1 - CONFIGURATION OF THE SENSOR TYPE .....	11
7.2 - SELECTION OF THE MOTOR TYPE .....	12
7.3 - ENCODER COUNTING PROTECTION.....	12
7.4 - PARAMETER ADJUSTMENT FOR A LINEAR MOTOR .....	13
7.5 - MAXIMUM APPLICATION SPEED .....	13
7.6 - CONFIGURATION OF THE THERMAL SENSOR.....	13
7.7 - $P_t$ PROTECTION.....	14
8 - SERVO LOOP ADJUSTMENT .....	15
8.1 - REGULATOR PARAMETERS .....	15
8.2 - LOOP ADJUSTMENT WITH A VERTICAL LOAD .....	16
9 - ROTATION / COUNTING DIRECTION .....	16
10 - PARAMETER SAVING.....	16
11 - MOTOR PHASING AT POWER ON.....	17
12 - INCREMENTAL ENCODER OUTPUTS.....	17
13 – POSITION LOOP SETUP.....	18
14 – APPLICATIONS WITH THE SECOND SENSOR INPUT .....	18
14.1 – SECOND POSITION SENSOR FEEDBACK .....	19
14.2 - ELECTRONIC GEARING APPLICATION.....	20
15 - COGGING TORQUE COMPENSATION.....	21
<b>CHAPTER 3 – FUNCTIONALITIES.....</b>	<b>23</b>
1 - DESCRIPTION OF THE LOGIC I/Os .....	23
1.1 - LOGIC INPUTS .....	23
1.2 - LOGIC OUTPUTS .....	23
2 - LIMIT SWITCHES ADJUSTMENT .....	24
3 - BRAKE CONTROL.....	25
4 - PROFIBUS ADDRESS.....	25
4.1 - PROFIBUS SOFTWARE ADDRESSING.....	25
4.2 - PROFIBUS HARDWARE ADDRESSING .....	25
<b>CHAPTER 4 - PROGRAMMING.....</b>	<b>26</b>
1 – GENERAL DESCRIPTION.....	26
2 – POSITIONER CONFIGURATION .....	26
2.1 – POSITION SCALING.....	26
2.2 – POSITION LIMIT AND SAFETY.....	27
2.3 – MANUAL MOVEMENTS.....	28

2.4 – BRAKE CONTROL AND AMPLIFIER DISABLING .....	28
2.5 – POSITIONING PROFILE .....	29
2.6 – POSITION MODULO .....	29
2.7 – POSITIONER I/Os .....	29
2.8 – SECOND SENSOR.....	30
2.9 – PROFIBUS COMMUNICATION .....	30
3 – EDITION OF A SEQUENCE .....	30
3.1 - HOMING SEQUENCE.....	32
3.2 - POSITIONING SEQUENCE.....	33
3.3 - SPEED SEQUENCE.....	34
3.4 - TORQUE SEQUENCE .....	34
3.5 - GEARING SEQUENCE .....	35
3.6 - SEQUENCES CHAINING.....	35
3.7 - PROGRAMMABLE OUTPUTS.....	37
3.8 - PROGRAMMABLE INPUTS.....	37
4 - PROGRAMME EXECUTION.....	37
5 - SPEED LIMITATION .....	38
<b>CHAPTER 5 – PROFIBUS COMMUNICATION .....</b>	<b>39</b>
<b>CHAPTER 6 – TROUBLESHOOTING.....</b>	<b>40</b>
1 - DIAGNOSTICS.....	40
1.1 - XtrapulsCD1-pm FAULT LEDs .....	40
1.2 – FAULT RESET .....	40
2 – FAULT FINDING .....	40
2.1 – SYSTEM FAULT .....	40
2.2 – NON STORED FAULTS .....	40
2.3 – STORED FAULTS .....	40
3 – OPERATING PROBLEMS.....	45
3.1 – MOTOR DOES NOT MOVE .....	45
3.2 – MOTOR SUPPLIED BUT NO TORQUE.....	45
3.3 – SHAFT LOCKED, ERATIC OSCILLATIONS OR ROTATION AT MAXIMUM SPEED .....	45
3.4 – DISCONTINUOUS MOTOR ROTATION WITH ZERO TORQUE POSITIONS .....	45
3.5 – LOUD CRACKLING NOISE IN THE MOTOR AT STANDSTILL.....	45
3.6 – LOUD NOISE IN THE MOTOR AT STANDSTILL AND WHEN RUNNING .....	46
3.7 – SEQUENCE NOT EXECUTED.....	46
4 - SERVICE AND MAINTENANCE .....	46
<b>APPENDIX .....</b>	<b>47</b>
1 - SERVO CONTROLLER STRUCTURE .....	47
2 – USE OF THE SERIAL LINK .....	48
2.1 – OVERVIEW.....	48
2.2 - INSTRUCTIONS LIST .....	49
3 - USE OF THE VT 100 TERMINAL .....	52
3.1 - CONFIGURATION.....	52
3.2 – USE OF THE TERMINAL .....	53
3.3 – FAULT DISPLAY.....	55

# Chapter 1 - General description

## 1 - INTRODUCTION

Series XtrapulsCD1-pm Profibus positioners are PWM servo amplifiers for the control of AC sinusoidal motors (brushless) equipped with a position sensor.

The XtrapulsCD1-pm servo drive is available as a stand-alone single-axis block that includes all supplies and mains filter. It is available in both mains operated versions 230 VAC and 400/480 VAC.

The XtrapulsCD1-pm positioner generates itself the positioning trajectory and is suited for axis positioning applications. Up to 128 control sequences including axis homing, absolute or relative displacement, speed profile running, electronic gearing and torque regulation can be programmed and combined in order to solve various applications. The sequence chaining capability allows defining macro-sequences for complex applications: several control sequences can be linked together in order to be automatically executed one after the other. The control sequences are pre-programmed. So, the application programming simply consists in initializing the sequences parameters with the desired values. A control sequence can then be selected by using the programmable logic inputs and its execution is started by using the START logic input. The XtrapulsCD1-pm positioner can operate in stand-alone mode or in connection with a host controller (PROFIBUS mode).

The selection of the various operation modes is made by means of micro-switches accessible by the operator.

### 1.1 – PROFIBUS MODE WITH SOFTWARE ADDRESSING

This mode is activated by the **00** micro-switches selection.

This operation mode is fully compliant with the CD1-p positioner.

The positioner Profibus address is saved into a non volatile memory (EEPROM). This EEPROM can be modified via Profibus (message Set\_Slave\_Add) by a Profibus master of class 2. The new address will be automatically saved.

### 1.2 – PROFIBUS MODE WITH HARDWARE ADDRESSING

This mode is activated by the **01** to **7D** micro-switches selections (Profibus address valid for one slave: 3 to 125).

In this mode, the drive address is defined by the micro-switches status and not by the serial link or by Profibus. The address modification via Profibus is still possible but the address taken into account at the next power up is always the one defined by the selection micro-switches.

### 1.3 – STAND-ALONE MODE

This mode is activated for the **7E** and **7F** combinations of the selection micro-switches:

- The **7E** combination corresponds to the stand-alone mode with VT100.
- The **7F** combination corresponds to the stand-alone mode without VT100.

In this mode, the Profibus is not used. The positioner operation is managed by the inputs **START**, **STOP**, **IN1** to **IN6** as well as by the outputs **SEQ**, **POS**, **SPEED**, **OUT1** to **OUT4**.

The **ENABLE** input enables/disables the positioner. The positioner cannot be enabled/disabled via the serial link RS-232 or by the Profibus. Consequently, **the positioner adjustment phase (autophasing, autotuning, cogging torque acquisition ...) must not be made in stand-alone mode**. In stand-alone mode, the brake delay time with regard to the enabling/disabling is not possible either.

## 2 - ARCHITECTURE OF A POSITIONER

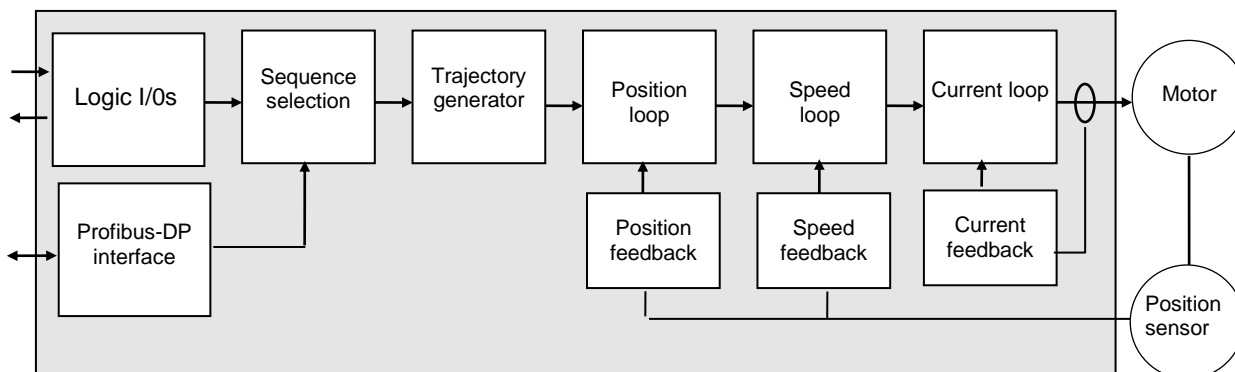

<b>Electric motor</b>	Electric device that transforms electrical energy into a mechanical movement. This transformation is often made by means of a current commutation. Generally, the movement is a rotation but there are also linear motors.
<b>Motor</b>	Electric motor which current commutation is made by mechanical brushes.
<b>Brushless or synchronous motor</b>	Electric brushless motor. The current commutation is electronically made and requires a position sensor (resolver, encoder, Hall sensor...).
<b>Resolver</b>	Absolute position sensor over one revolution. The resolver is often used together with brushless motors because of its robustness.
<b>Encoder</b>	Incremental or absolute position sensor. The encoder is used together with brushless motors for its accuracy.
<b>Amplifier</b> Servo drive	Electric device for the control of electric motors. It also includes a current regulator, a speed servo control and, a position servo control.
<b>Current loop</b> Current regulator	Used for the motor current control. The motor torque is generally proportional to the current amplitude.
<b>Speed loop</b> Speed regulator	Allows the motor speed control with a speed input command.
<b>Position loop</b> Position regulator	Allows the motor position control.
<b>Positioner</b>	Positioner with position loop and trajectory generator that allows positioning.
<b>Trajectory generator</b>	Generates a speed profile (acceleration, step speed, deceleration) that allows positioning (start position -> arrival position).
<b>Fieldbus</b>	Digital link that allows real time data exchange between various electric devices. The characteristic of field busses is their high protection and fault correction level as well as a predictable communication time.
<b>Profibus</b>	Fieldbus initially defined by Siemens®. This bus is widely used in automation.
<b>Enabled/disabled</b> (Servo On/Off)	When a motor is enabled, it is controlled by the positioner and the servo loops are operating. When disabled, its rotation is free and there is no current in the motor.

## 3 - OTHER DOCUMENTS REQUIRED FOR THE COMMISSIONING

- ◆ " XtrapulsCD1-pm Profibus positioner Installation Manual".
- ◆ " XtrapulsCD1-pm Profibus Communication Profile".



# Chapter 2 - Commissioning



**WARNING**

During the machine adjustments, some drive connection or parameterization errors may involve dangerous axis movements. It is the user's responsibility to take all necessary steps in order to reduce the risk due to uncontrolled axis movements during the operator's presence in the concerned area.

## 1 – COMMISSIONING OVERVIEW

The various stages of a first positioner commissioning are described below:

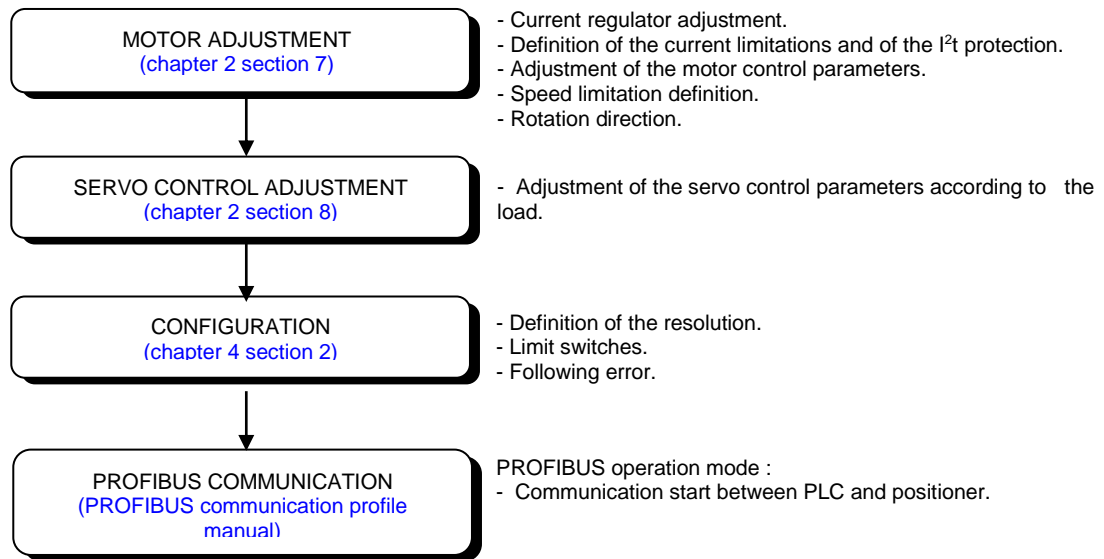

Both operation stages are:

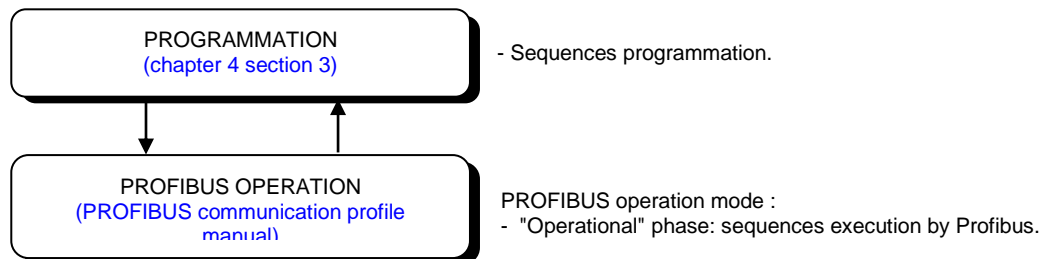

The positioner parameters are accessible via:

- the serial link and the PC parameterization software,
- or by the PKW of the PROFIBUS DP.

**CAUTION !**

Do not make the drive parameterization by means of both PC software and Profibus at the same time.

## 2 – INSTALLATION OF THE PC SOFTWARE

The **Visual Drive Setup** software is PC compliant under Windows®<sup>1</sup> and allows an easy parameterization of the XtrapulsCD1-pm amplifiers.

Please see our website [www.infranor.com](http://www.infranor.com) for downloading the "Visual Drive Setup" software.

## 3 - CHECKING THE POSITIONER HARDWARE CONFIGURATION

The standard amplifier configuration is adjusted to MAVILOR motors (resolver sensor with transformation ratio = 0.5). For the adjustment to other motor types, please see "[XtrapulsCD1-pm - Installation Guide](#)".

## 4 - SELECTION OF THE OPERATION MODE

A DIP micro-switch, accessible by the operator, allows the selection of the various operation modes.

7 6 5 4 3 2 1 (Switch 7 = MSB Switch 1 = LSB)	Operation mode	Note
X0000000 (00)	Profibus software addressing	This mode is compliant with the CD1-p drive Drive address is stored into the EEPROM
X0000001 (01) to X1111101 (7D)	Profibus hardware addressing	Profibus mode with hardware addressing via "DIP" switch
X1111111(7F)	Stand-alone Mode without VT100	Drive used in Positioner mode via inputs START, STOP, IN1 to IN6
X1111110(7E)	Stand-alone Mode with VT100	Drive used in Positioner mode via inputs START, STOP, IN1 to IN6 Possible use of a VT100 terminal

X: Cursor unused.

Remark: The positioner automatic procedure for the commissioning phase (autophasing, autotuning, cogging torque acquisition ...) cannot be started in the stand-alone operation mode .

## 5 - COMMISSIONING

Please see manual "[XtrapulsCD1-pm - Installation Guide](#)" before switching on the amplifier for the first time.

For switching on the amplifier, please proceed as follows:

- Switch on the +24V auxiliary supply:

The red front panel LED "**ERROR**" must be unlit and the red front panel LED "**AP**" must be lit ("Undervolt." error displayed).

The AOK relay contact (pins 1 and 2 of X4) is closed. It is then possible to control the power ON relay.

- Switch on the power supply:

The red front panel LED "**AP**" must be unlit : the amplifier is ready for enabling.

### **CAUTION!**

The 24 V auxiliary supply must **always** be switched on **before** the power supply.

It is mandatory to wait for at least 30 seconds between switching off and on again the amplifier.

<sup>1</sup> Windows® is a registered trade mark of MICROSOFT® CORPORATION

## 6 - STARTING THE "VDSETUP" SOFTWARE

- Connect the serial link RS232 between PC and amplifier.
- Switch on the amplifier and start the **Visual Drive Setup** software on the PC, under WINDOWS®.

If the message **No serial communication found** is displayed on the screen, click on OK and check the following points:

- The amplifier must be on,
- The correct RS232 connection between amplifier and PC,
- The correct software configuration (**Com.port**, ...).

For the parameterization of the amplifier via the **Visual Drive Setup** software, set all DIP micro-switches at position OFF (address 00).

## 7 - MOTOR ADJUSTMENT

### 7.1 - CONFIGURATION OF THE SENSOR TYPE

The configuration of the sensor type is software selectable and saved in the amplifier EEPROM.

The amplifier is configured as standard for a resolver sensor. For motors equipped with an encoder, please proceed as follows:

- ◆ Select the appropriate encoder type in the **Resolver & Encoder input configuration** menu.
- ◆ Select **Encoder feedback** and confirm this selection.
- ◆ Then enter the **Motor encoder Resolution** value in the **Servo Motor** module.

If the motor is equipped with Hall effect sensors, check that the ENABLE input is not activated and the amplifier is on, before moving manually the motor over one revolution or one pole pitch on linear motors. If the **HES** error is displayed, switch off the amplifier and check the following points before switching it on again:

- ◆ The Hall effect sensors (HES) must be correctly connected on the amplifier X3 connector (if 60° Hall sensor types are used, check the various wiring combination of the HES signals for finding the right wiring order).
- ◆ Check for the correct supply voltage of the Hall sensors.
- ◆ Check for the correct value of the **Motor encoder Resolution** parameter.

If the motor Hall sensors do not work correctly, select the appropriate incremental encoder type (**Incremental Encoder** without HES) in the **Feedback configuration** menu and start the amplifier commissioning with this configuration.

If the motor used is equipped with an absolute Sin/Cos encoder over one revolution (Heidenhain ERN 1085 or compliant), check that the ENABLE input is not activated and the amplifier on. Then move manually the motor over one revolution. If the **HES** error is displayed, switch off the amplifier and check the following points before switching it on again:

- ◆ The commutation channels of the Sin/Cos encoder must be correctly wired on the amplifier X3 connector.
- ◆ Check for the correct supply voltage of the Sin/Cos encoder.
- ◆ Check for the correct value of the **Motor encoder resolution** parameter.

Perform the **Save parameters to EEPROM** procedure before switching off the amplifier in order to save the sensor configuration.

## 7.2 - SELECTION OF THE MOTOR TYPE

THE MOTOR USED IN THE APPLICATION IS CONTAINED IN THE MOTOR LIST OF THE PARAMETERIZATION SOFTWARE.

Select, in the motor list, the motor used in the application.  
The motor selection will start the automatic calculation of the current loop parameters.

Check that the values of the parameters **Max. current** and **Rated current** are compliant with motor and amplifier.  
If necessary, modify them according to the motor and amplifier specifications.

The parameter **Max current** defines the maximum output current value of the amplifier. It may vary between 20 % and 100 % of the amplifier current rating.

The parameter **Rated current** defines the limitation threshold of the amplifier output RMS current ( $I^2t$ ).  
It can vary between 20 % and 50 % of the amplifier current rating.

If the **Incremental encoder without HES** sensor configuration is selected, start a motor phasing (**Phasing**) procedure.  
The motor phasing can be launched either in the control window of the **VISUAL DRIVE SETUP** software, via the PROFIBUS fieldbus, or via the **Enable** input in stand-alone mode.

THE MOTOR USED IN THE APPLICATION IS NOT CONTAINED IN THE MOTOR LIST OF THE PARAMETERIZATION SOFTWARE.

Select the **New Motor** function and follow the instructions.

## 7.3 - ENCODER COUNTING PROTECTION

When servo motors are equipped with an encoder, any error in the encoder pulse counting generates an error in the position measurement of the rotor and may involve uncontrolled motor movements that can be dangerous for both operator and machine. The encoder counting protection of the XtrapulsCD1-pm amplifier range allows the detection of pulse counting errors and immediately disables the amplifier for reasons of security.

The encoder counting protection checks that the number of encoder pulses between two successive Z marker pulses (or R reference signals) is equal to the value of the **Motor encoder resolution** parameter multiplied by the one of the **Zero mark pitch** parameter. The encoder counting protection also checks that the encoder pulse frequency is lower than 1,5 times the maximum encoder frequency. The maximum encoder frequency is calculated in the amplifier according to the value of the **Motor encoder resolution** and **Maximum speed** parameters.

The value of the **Motor encoder resolution** parameter defines the number of encoder pulses (or encoder signal periods) per motor revolution (for a rotary motor) or per motor pole pairs (for a linear motor).

The value of the **Zero mark pitch** parameter defines the number of motor revolutions (for a rotary motor) or of motor pole pairs (for a linear motor) between two successive Z marker pulses (or R reference signals).

With a rotary motor, the **Zero mark pitch** parameter is generally equal to 1 because the encoder has got one Z marker pulse (or one R reference signal) per motor revolution.

On a linear motor with only one marker pulse over the whole motor travel, the **Zero mark pitch** parameter must be defined at 15. In this case, the encoder counting protection checks that the measured encoder position has still got the same value when the marker pulse is activated (no drift in the position measurement).

**Note:** In the **Incremental encoder without HES** configuration, the motor phasing procedure (**Phasing**) must be renewed after the release of a **Counting** error because the current rotor position reference for the motor commutation is not correct.

## 7.4 - PARAMETER ADJUSTMENT FOR A LINEAR MOTOR

The **Motor encoder resolution** parameter is calculated as follows:

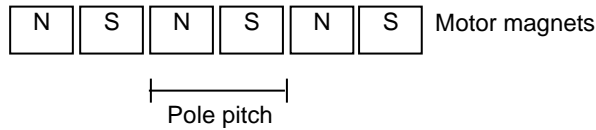

$$\text{Motor encoder resolution} = 1000 \times \frac{\text{Motor pole pitch (mm)}}{\text{Encoder signal pitch (\mu\text{m})}}$$



1 encoder signal pitch = 4 counting increments

The value of the motor **Maximum speed** parameter in rpm is calculated as follows:

$$\text{Max. speed (rpm)} = 60 \times \frac{1000}{\text{Motor pole pitch (mm)}} \times \text{max. motor speed (m/s)}$$

The linear speed value in m/s is calculated as follows:

$$\text{Linear speed (m/s)} = \frac{\text{Motor speed (rpm)}}{60} \times \frac{\text{Motor pole pitch (mm)}}{1000}$$

## 7.5 - MAXIMUM APPLICATION SPEED

The parameter **Max. speed** defines the maximum speed at which the amplifier can control the motor. This parameter can be:

- lower than or equal to the maximum motor speed,
- slightly higher than the maximum motor speed in the application (20%). This margin allows a speed overshoot that avoids the position loop saturation (position following). This margin can be as small as possible when using a high bandwidth or at low acceleration.

The speed set point value for the sequences and for the manual movements (positioning and jog) are saved in % with regard to the **Max. speed** parameter value. So, when the **Max. speed** parameter value is changed, all speed set point values are scaled accordingly.

## 7.6 - CONFIGURATION OF THE THERMAL SENSOR

According to the selected position feedback sensor of the motor, the thermal sensor is entering either the X1 connector (resolver) or the X3 connector (encoder).

### 7.6.1 – SELECTION OF THE SENSOR TYPE

The motor can be equipped either with a CTN sensor (ohmic resistance = decreasing temperature function) or with a CTP sensor (ohmic resistance = increasing temperature function).

Check that the selected thermal sensor type actually corresponds to the sensor type mounted on the application motor.

### 7.6.2 – TRIGGERING THRESHOLD ADJUSTMENT

Enter the sensor ohmic value (kOhm) corresponding to the required temperature value for the release of the **Motor overtemperature** protection, according to the manufacturer's specifications.

### 7.6.3 – WARNING THRESHOLD ADJUSTMENT

Enter the sensor ohmic value (kOhm) corresponding to a warning temperature value.  
When the warning temperature is reached, the red front panel LED "ERROR" is blinking.

Note: When using a CTN sensor, the warning ohmic value will be higher than or equal to the triggering ohmic value.

When using a CTP sensor, the warning ohmic value will be lower than or equal to the triggering ohmic value.

## 7.7 - I<sup>2</sup>t PROTECTION

2 selection modes are available: **Fusing** or **Limiting**.

It is advisable to use the **Fusing** mode during commissioning phases.

In **Fusing** mode, the amplifier is disabled when the current limitation threshold is reached.

In **Limiting** mode, the motor current is only limited at the value defined by the **Rated current** parameter when the limitation threshold is reached.

### 7.7.1 - OPERATION OF THE CURRENT LIMITATION IN "Fusing" mode

When the amplifier output RMS current (I<sup>2</sup>t) reaches 85 % of the rated current, the red **ERROR** LED is blinking on the amplifier front panel (t1 in the diagram). If the RMS current (I<sup>2</sup>t) has not dropped below 85 % of the rated current within 1 second, the I<sup>2</sup>t error is released and the amplifier disabled, otherwise, the blinking is inhibited (t3 in the diagram).

When the amplifier output RMS current (I<sup>2</sup>t) reaches the rated current value, the I<sup>2</sup>t limits the amplifier output current at this value (t2 in the diagram).

Diagram of the amplifier output current limitation in an extreme case (motor overload or shaft locked):

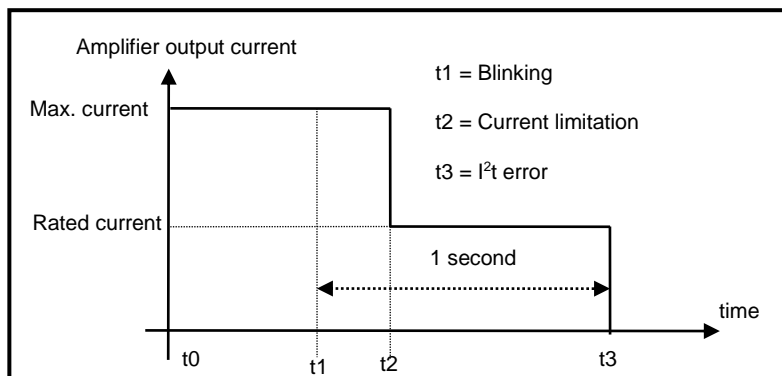

The maximum current duration before release of the blinking display is depending on the value of the parameters **Rated current** and **Max. current**. This value is calculated as follows:

$$T_{\text{dyn}} (\text{second}) = t_1 - t_0 = 3,3 \times [\text{Rated current (A)} / \text{Max. current (A)}]^2$$

The maximum current duration before limitation at the rated current is also depending on the value of the **Rated current** and **Maximum current** parameters. This value is calculated as follows:

$$T_{\text{max}} (\text{second}) = t_2 - t_0 = 4 \times [\text{Rated current (A)} / \text{Max. current (A)}]^2$$

#### NOTE 1

When the "**Max. current** / **Rated current**" ratio is equal to 1, the I<sup>2</sup>t error is never released. But these formulas remain very precise as long as the "**Max. current** / **Rated current**" ratio is higher than 3/2.

**NOTE 2**

The amplifier  $I^2t$  signal can be displayed on the digital oscilloscope by selecting the  $I^2t$  signal in the **Channel** menu. The threshold values of the  $I^2t$  signal, for the protection mode described above, are calculated as follows:

$$\text{Current limitation threshold (\%)} = [\text{Rated current (\%)}]^2 / 50$$

$$\text{Rated current (\%)} = 100 \times \text{Rated current (A)} / \text{amplifier current rating (A)}$$

The corresponding RMS current value of the amplifier can be calculated as follows:

$$\text{Amplifier RMS current (A)} = [I^2t \text{ signal value (\%)} \times 50]^{1/2} \times \text{amplifier current rating (A)} / 100$$

**7.7.2 - CURRENT LIMITATION IN "Limiting" MODE**

When the amplifier output RMS current ( $I^2t$ ) reaches 85 % of the rated current, the red **ERROR** LED on the amplifier front panel is blinking (t1 in the diagram). When the RMS current ( $I^2t$ ) drops below 85 % of the rated current, the blinking is inhibited.

When the amplifier output RMS current ( $I^2t$ ) reaches the rated current value, the  $I^2t$  protection limits the amplifier output current at this value (t2 in the diagram).

Diagram of the amplifier output current limitation in an extreme case (motor overload or shaft locked):

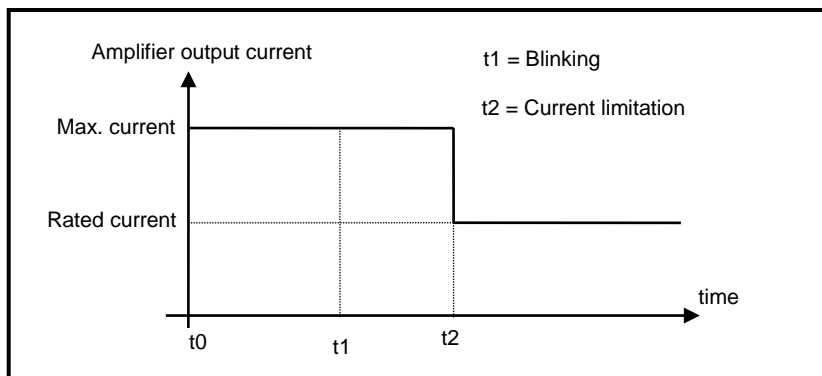

The maximum current duration before release of the blinking display (t1 - t0) and before limitation at the rated current (t2 - t0) is calculated the same way as in the "Fusing" mode.

**8 - SERVO LOOP ADJUSTMENT****8.1 - REGULATOR PARAMETERS**

The **Autotuning** procedure identifies the motor and load specifications and calculates the speed/position loop parameters.

In **P** and **PI** speed mode, only the speed loop gains are calculated.

In **PI<sup>2</sup>** speed mode, the proportional gain of the position loop is also calculated. But the **Feedforward** gains of the position regulator are all initialized at 0.

In **Position** mode, all gains of both speed and position regulators are calculated.

**Note:** The position loop stability can be tested in **PI<sup>2</sup>** speed mode because the **Feedback** gains are identical to the **Position** mode.

The operator can select a bandwidth (**Low**, **Medium** or **High**) as well as the filter type (**standard**, **antiresonance** or **max. stiffness**).

The **Autotuning** procedure can be executed with the motor disabled or enabled. In the case of an axis with a vertical load, see section 8.2 of this chapter.

Before executing the **Autotuning** procedure, check that the motor shaft is free and that its rotation over one revolution is not dangerous for operator and machine. Check that the brake is released (the **Autotuning** command does not control the brake).

For a complete adjustment, the **Autotuning** procedure must **always** be executed in **Position** mode (at power on, the amplifier is automatically in **Position** mode).

But the amplifier position loop stability can also be tested in **Speed** mode. In this case, after the execution of the **Autotuning** procedure in **PI<sup>2</sup>** mode:

- check that the motor is correctly running in both directions,
- check the **response at a small displacement without Idc saturation** (oscilloscope function).

In case of loud noise in the motor at standstill or when running, check the rigidity of the mechanical transmission between motor and load (backlashes and elasticities in motor and couplings).

If required, start a new **Autotuning** procedure by selecting a lower bandwidth.

If the instability remains, start a new **Autotuning** procedure by activating the **Antiresonance** filter. If necessary, adjust more accurately the loop response stability by adjusting the stability gain.

If the **Autotuning** procedure was executed in **PI<sup>2</sup>** mode, when the **Position** mode was selected, the **Feedforward** gains of the position regulator must be adjusted manually. Set the **Feedforward speed 1** gain value at 1, in order to avoid a high following error value.

## 8.2 - LOOP ADJUSTMENT WITH A VERTICAL LOAD

In the case of an axis with vertical load, proceed as follows:

Select the **Limiting** current limitation mode.

Initialize the speed loop gains corresponding to the unloaded motor (execute therefore the **Autotuning** procedure with the motor uncoupled from its mechanical load).

Couple the motor with its load. If possible, make a control in speed mode; otherwise, close the position loop with a stable gain.

Select the **PI<sup>2</sup>** speed mode and move the axis by means of the speed input command until a stall position where one motor revolution is not dangerous for operator and machine (far enough from the mechanical stops).

Execute then the **Autotuning** procedure with the motor at standstill. If the axis is moving, the **Autotuning** procedure is not accepted by the amplifier.

Select the **Position** mode and set the **Feedforward speed 1** gain value at 1, in order to avoid a high following error value.

## 9 - ROTATION / COUNTING DIRECTION

The counting direction can be reversed by selecting the **Reverse movement** in the **Visual Drive Setup** parameterization software.

## 10 - PARAMETER SAVING

When all adjustments have been made, the parameters may have to be **stored** in a non volatile EEPROM (the amplifier must be disabled).



## 11 - MOTOR PHASING AT POWER ON

In the Incremental encoder configuration without HES, the motor Phasing procedure is executed according to the following diagram at each amplifier power up (standalone mode) :

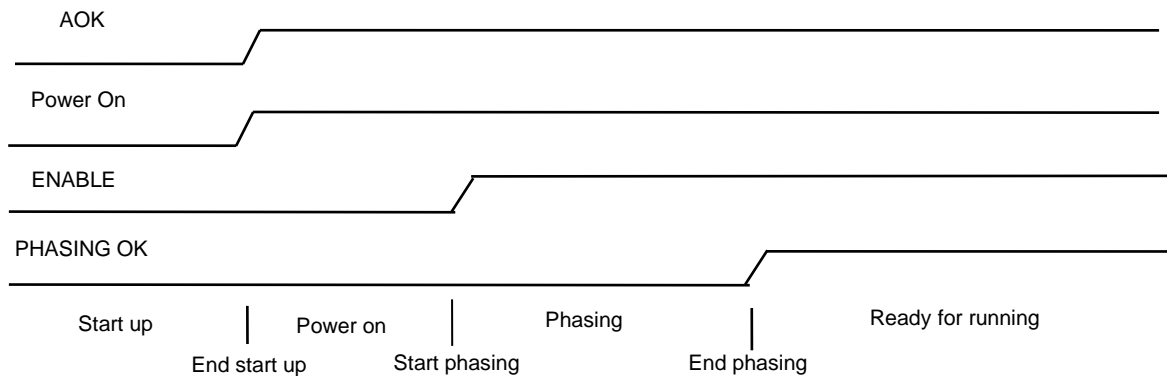

In the Profibus mode, the phasing procedure must be started by the master controller (PNU 896). In the Software control mode via the serial link, the phasing procedure must be started by the Motor phasing command in the **VDSetup** window.



In the case of an axis with unbalanced load (constant torque due to the gravity effect on a vertical axis), the motor phasing procedure is not valid. The motor must be equipped with an incremental encoder + HES or an absolute Sin/Cos encoder.

**Remark:** In the Incremental encoder configuration without HES, the motor **Phasing** procedure must be carried out again after a **Feedback** fault release or a **Counting** fault release. The motor **Phasing** procedure must also be carried out again after the modification of the motor or the encoder parameter value.

- The analog output on the X2 connector can be configured in the **Setup** menu of the **VISUAL DRIVE SETUP** software in order to get the **Phasing OK** output signal (output voltage from 0 V to 10 V when the motor phasing is OK) .
- In the Profibus mode, the **Phasing OK** can be checked by the master controller (PNU 897).
- In the Software control mode via the serial link, the state of the **Phasing OK** output is displayed in the main **VDSetup** window.

## 12 - INCREMENTAL ENCODER OUTPUTS

The incremental encoder outputs are two pulse channels A and B in quadrature and one Z marker pulse per revolution.

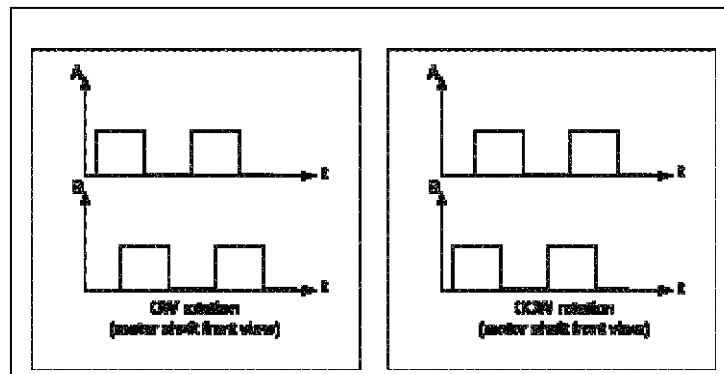

The **Output encoder resolution** is selected according to the table below:

Maximum motor speed (rpm)	up to 1600	up to 3200	up to 6400	up to 12800	up to 25000
Encoder output resolution (ppr)	512 to 16384	512 to 8192	512 to 4096	512 to 2048	512 to 1024

The resolution value defined in the **Output encoder resolution** parameter can be divided by 2, 4 or 8 by selecting the **Resolution division ratio** parameter.

The **Output encoder deadband** parameter introduces a deadband at standstill around the current resolver position in order to avoid oscillations of +/- 1 encoder edge on channels A and B. The value of 4095 corresponds to 1/16 revolution of the motor shaft.

The **Zero pulse origin shift** parameter allows the shifting of the marker pulse position on channel Z with regard to the resolver zero position. The value 32767 corresponds to one revolution of the motor shaft. The marker pulse width is equal to  $\frac{1}{4}$  of the A and B channels period.

## 13 – POSITION LOOP SETUP

The servo motor position loop can be closed by the motor feedback sensor or with the second position sensor mounted on the load. In the case of the second position sensor feedback, [please see section 14.1](#) of this chapter.

Open the "**Position scaling parameters**" window accessible in the "**Positioner Application Setup**" menu.

Check that "**Enable second sensor feedback**" is not selected, in order to use the motor position sensor (resolver or encoder) for feedback.

Set the "**Position resolution**" parameter according to the desired position scaling of the load in order to display the position in the load units as described below:

Position resolution = number of desired load position increments for one motor revolution

Ex: one motor revolution = 3.302 mm on the load, if the load position must be displayed in mm with a resolution of 1µm. Choose Position resolution = 3302, Decimal number = 3 and Unit = mm.

The servo loop stability is not affected by the **Position Resolution** parameter value.

Set at 0 the value of the "**Position deadband**" parameter. This parameter is only useful in applications with high transmission backlashes or applications with high axis frictions. In those cases, when the position error value at standstill is lower than the value of the "**Position deadband**" parameter, the proportional gain of the position loop is set at 0.

## 14 – APPLICATIONS WITH THE SECOND SENSOR INPUT

The XtrapulsCD1-pm amplifier has got 2 position sensor inputs : one for a resolver and another for an encoder. The position sensor input which is not used for the motor position feedback (encoder or resolver) is called **Second Position Sensor** input. The **Second Position Sensor** input can be used for closing the drive position loop if a position sensor is mounted on the motor load . The **Second Position Sensor** input can also be used for an electronic gearing application.

## 14.1 – SECOND POSITION SENSOR FEEDBACK

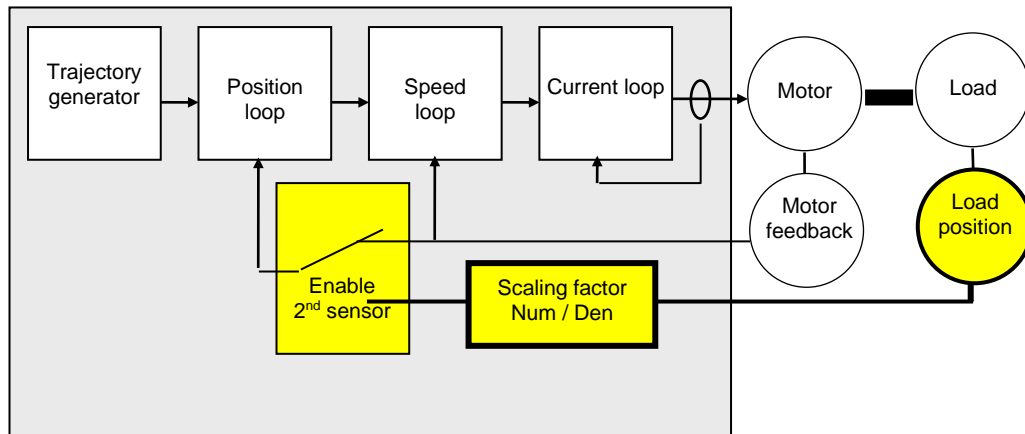

Resolver sensor feedback for the motor, and TTL incremental encoder for the second sensor is the default configuration.

Select the required position sensor configuration in the "**Resolver & encoder input configuration**" window accessible in the "**Setup**" menu.

Open the "**Position scaling parameters**" window accessible in the "**Positioner Application Setup**" menu.

Select "**Enable second sensor feedback**" to use the second position sensor (encoder or resolver) for closing the drive position loop. When this command is not selected, the drive position loop is using the motor position sensor (resolver or encoder) for feedback.

Set the "**Position resolution**" parameter according to the desired position scaling of the load in order to display the position in the load units as described below:

Position resolution = number of desired load position increments for one motor shaft revolution.

Enter the desired "Decimal" number and the "Unit" for the position display.

Ex: one motor revolution = 3.302 mm on the load, if the load position must be displayed in mm with a resolution of 1µm, choose Position resolution = 3302, Decimal number = 3 and Unit = mm.

Remark: In the second sensor feedback configuration, the servo loop stability is affected by a wrong Position resolution parameter value.

Set at 0 the value of the "**Position deadband**" parameter. This parameter is only useful in applications with high transmission backlashes or applications with high axis frictions. In those cases, when the position error value at standstill is lower than the value of the "**Position deadband**" parameter, the proportional gain of the position loop is set at 0.

Open the "**Second Sensor**" window accessible in the "**Positioner Application Setup**" menu.

Adjust the "**Position scaling factor**" (numerator / denominator) according to the desired load position scaling and the current load sensor resolution as described below:

- For an encoder sensor type on the load:

Position scaling factor Numerator = "Position resolution" parameter value (see "**Position scaling parameters**" window).

Position scaling factor Denominator = 4 x number of encoder pulses/channel for one motor shaft revolution.

- For a resolver sensor type on the load:

Position scaling factor Numerator = "Position resolution" parameter value (see "**Position scaling parameters**" window).

Position scaling factor Denominator = 65536 x number of resolver shaft revolution for one motor shaft revolution.



**REMARK:**

If the calculated Numerator and Denominator values exceed the parameters max. value (65535), they must be scaled in order to get the same ratio (Numerator / Denominator) or to be as close as possible to the theoretical value: scaled Numerator / scaled Denominator = calculated Numerator / calculated Denominator.

Select "**Reverse position**" to reverse the counting direction of the second position sensor if required.

When the second position sensor is a SinCos encoder type, select "**Pulse interpolation**".

Enable the amplifier and check that the motor and load positions are stable. If the motor is moving (and then the following error is released), the sign of the load position feedback is not correct. In this case, select the "**Reverse position**" command in the "**Second sensor**" window.

## 14.2 - ELECTRONIC GEARING APPLICATION

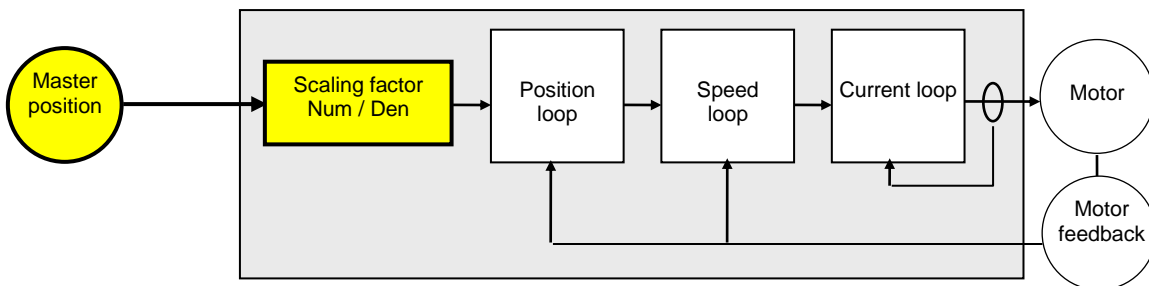

Electronic gearing applications require the use of the second amplifier position sensor for measuring the displacements of the master axis.

If the motor is equipped with a resolver, select the encoder type for the input of the second sensor in the "**Resolver & encoder input configuration**" window accessible in the "**Setup**" menu.

Open the "**Position scaling parameters**" window accessible in the "**Positioner Application Setup**" menu.

Check that "**Enable second sensor feedback**" is not selected.

Set the "**Position resolution**" parameter according to the desired position scaling of the load in order to display the position in the load units as described below:

Position resolution = number of desired load position increments for one motor shaft revolution

Enter the desired "Decimal" number and the "Unit" for the position display.

Ex: one motor revolution = 3.302 mm on the load, if the load position must be displayed in mm with a resolution of 1 μm, choose Position resolution = 3302, Decimal number = 3 and Unit = mm.

Set at 0 the value of the "Position deadband" parameter. This parameter is only useful in applications with high transmission backlashes or applications with high axis frictions. In those cases, when the position error value at standstill is lower than the value of the "**Position deadband**" parameter, the proportional gain of the position loop is set at 0.

Open the "**Second Sensor**" window accessible in the "**Positioner Application Setup**" menu.

Adjust the "**Position scaling factor**" (numerator / denominator) according to the desired gearing ratio as described below:

- For an electronic gearing application with an encoder sensor type on the master axis,  
 Gearing ratio = Gearing numerator / Gearing denominator = Motor shaft speed / Master encoder shaft speed.  
 Position scaling factor Numerator = ("Position resolution" parameter value) x Gearing numerator.  
 Position scaling factor Denominator = (4 x master encoder resolution) x Gearing denominator.

- For an electronic gearing application with a resolver sensor type on the master axis,  
 Gearing ratio = Gearing numerator / Gearing denominator = Motor shaft speed / Master resolver shaft speed.  
 Position scaling factor Numerator = ("Position resolution" parameter value) x Gearing numerator.  
 Position scaling factor Denominator = 65536 x Gearing denominator.



**REMARK:**

If the calculated Numerator and Denominator values exceed the parameters max. value (65535), they must be scaled in order to get the same ratio (Numerator / Denominator) or to be as close as possible to the theoretical value: scaled Numerator / scaled Denominator = calculated Numerator / calculated Denominator.

When the second position sensor is a SinCos encoder type, select "**Pulse interpolation**".

Enable the amplifier and select "**Enable gearing**" in the "**Software control**" window. Check that the slave axis actually follows the displacement of the master axis with the correct reduction ratio.

If the motion direction is not correct, select the "**Reverse position**" command in the "**Second sensor**" window.

If there is a loud noise in the motor during the axis motion, set at 0 the "**Feedforward acceleration**" gain. If using a SinCos master encoder, check also that the "**Pulse interpolation**" command is enabled in the "**Second sensor**" window.

## 15 - COGGING TORQUE COMPENSATION

The cogging torque in brushless permanent magnet rotary motors or the cogging force in brushless permanent magnet linear motors results from the interaction between the rotor magnets and the stator slots. This disturbance is due to the difference of reluctance between the copper of the windings and the iron of the stator teeth. For a given motor, the cogging can be easily evaluated by simply moving the motor manually when the amplifier is disabled. The Cogging compensation option available in the XtrapulsCD1 amplifier range allows cancelling the motor cogging effects for specific applications where torque accuracy or force accuracy higher than 1 % is required.

XtrapulsCD1 amplifiers must be factory set for getting the cogging compensation option (reference XtrapulsCD1-pm-U/I-CT). Check for the presence of the cogging compensation option (**CT-CD1**) in the **VDSetup** Hardware option menu. In this case, the **Cogging torque compensation** menu can be selected in the **Servo loop** module.



For a brushless motor equipped with an incremental encoder, the Cogging torque compensation is only available if the encoder is providing one marker pulse per motor revolution.

The cogging torque acquisition procedure is started by means of the **Start** button. The motor must be uncoupled from its load and the shaft must not be disturbed during the procedure. Before starting the acquisition, switch the drive on manual mode and then disable it (Drive control = Off). Then, start the **Auto-tuning** procedure with following selections: Regulator = PI<sup>2</sup>, Filter = Max. stiffness and Bandwidth = High. At the end of the cogging torque acquisition procedure, the amplifier parameter file (**\*.PAR**) can be uploaded again in order to recover the initial adjustments.

The **Enable cogging torque compensation** function allows the commissioning of the motor cogging torque compensation. This function is saved in the amplifier EEPROM.

The **Save cogging torque data into a file** function allows storing in a PC the cogging torque value corresponding to a motor after the acquisition procedure (**\*.COG** file).

The **Write cogging torque data into the drive** function allows uploading in the amplifier the cogging torque value corresponding to a motor, if this value has previously been stored in the PC (\*.COG file).



For a brushless motor equipped with an incremental encoder, the Cogging torque compensation is only available if the encoder is providing one marker pulse per motor revolution.

Note 1:

The motor cogging torque value is checked at the amplifier power up. If it contains some errors (storage problems in the amplifier memory), the EEPROM error is displayed and the **Enable cogging torque compensation** function is disabled.

Note 2:

When exchanging an amplifier on an axis, the file of the adjustment parameters (\*.PAR) as well as the cogging torque file (\*.COG) corresponding to the motor must be uploaded once again in the amplifier.

Note 3:

When exchanging the motor or when disassembling the resolver sensor, the acquisition procedure must be renewed.

## Chapter 3 – Functionalities

### 1 - DESCRIPTION OF THE LOGIC I/Os

#### 1.1 - LOGIC INPUTS

##### 1.1.1 - GLOBAL LOGIC INPUTS

**ENABLE** Enabling authorized. This signal is a necessary condition for the motor enabling.

**INDEX/CLR** Index input for the axis homing. This input can be used for resetting the position counter when this function is configured.

**FC+** Limit switch input, positive direction.

**FC-** Limit switch input, negative direction.

##### 1.1.2 - LOGIC INPUTS FOR THE SEQUENCE CONTROL

**START** This input allows starting the sequence which number is defined by the programmable inputs. The level of this input will be taken into account after the end of the former sequence. This signal can be disabled before the end of the sequence.

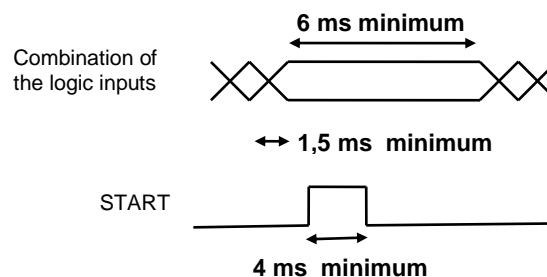

**STOP** This input stops the motor with the deceleration given by the JOG motion parameters.

**IN1 to IN6** These inputs allow defining, in natural binary code, the number of the sequence to be executed ("Sequence control" configuration). The activation of the START input will execute the sequence defined by the programmable inputs. These inputs also allow defining a sequence starting condition ("**Start condition**" configuration). The sequence will be executed if the inputs condition is answered.

#### 1.2 - LOGIC OUTPUTS

##### 1.2.1 - GLOBAL LOGIC OUTPUTS

**Amp OK** This signal indicates that the amplifier is ready (without error).

**BRAKE** This output controls the motor brake activation/desactivation.

### 1.2.2 - SEQUENCE CONTROLLED LOGIC OUTPUTS

- SEQ** This signal indicates that a sequence is presently executed.
- POS** This signal is activated when the motor reaches the position and remains enabled until the next motor movement.
- SPEED** This signal indicates that the speed set point is reached during a movement of the motor.

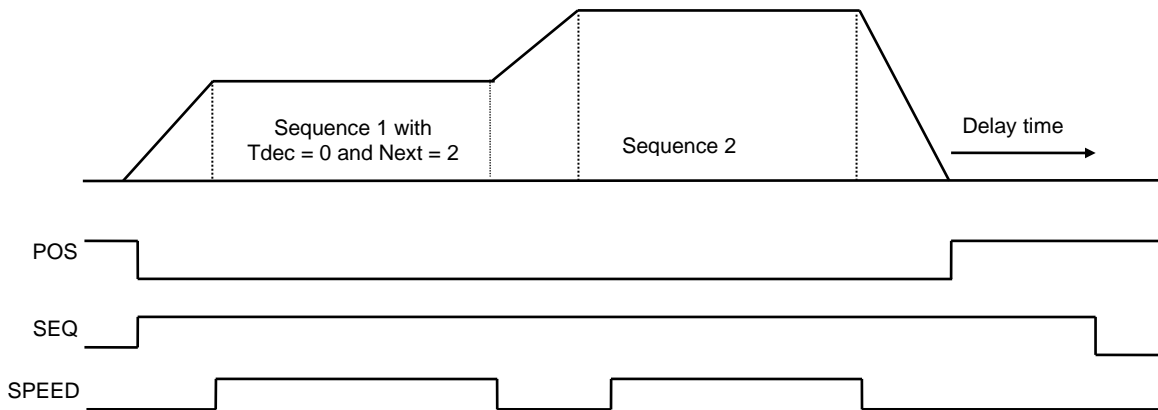

**OUT1 to OUT4** Programmable logic outputs. These outputs are only operating during a programmed sequence.

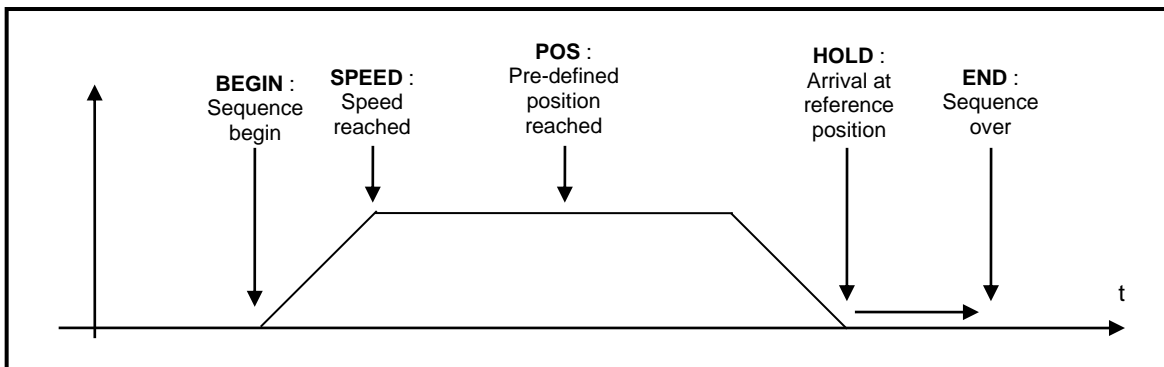

Programmable status: "High" status - "Low" status - "Toggle" status.  
 Various triggering types: **BEGIN, SPEED, POS, HOLD, END.**  
 These outputs can be triggered only once per programmed sequence.

## 2 - LIMIT SWITCHES ADJUSTMENT

The limit switch inputs are inputs for a proximity sensor that stops the motor with maximum deceleration. When both limit switches are correctly placed on the motor travel, they are a protection for the machine in case of incorrect movement.

The limit switches are only defined according to the physical motor rotation. They are not depending on the selected "rotation/counting direction".



For checking the limit switches:

- move the motor in one direction in speed mode,
- activate the limit switch which is located in the motion direction (artificially, if necessary),
- check that the motor is stopping,
- if the motor does not stop, the limit switches are reversed wired.

Check also in the opposite direction.

#### Notes

- The motor is stopped with maximum deceleration by a limit switch.
- Reminder: The limit switches are wired as "normally closed".

## 3 - BRAKE CONTROL

- The XtrapulsCD1-pm positioner is equipped with a brake control (made by transistor).
- The brake control is activated (relay open) or disabled (relay closed) according to the positioner status (disabled or enabled) as shown below.

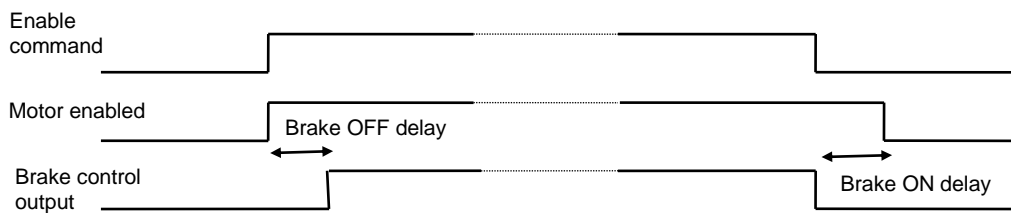

## 4 - PROFIBUS ADDRESS

### 4.1 - PROFIBUS SOFTWARE ADDRESSING

This operation mode is selected with all the DIP micro-switches on position OFF.

Each positioner of the network is identified by one single address (1 to 125). The positioner is delivered with the default software address 126, **which is not an operational address**. This address must be modified before putting the bus into operation.

The XtrapulsCD1-pm software address can be modified:

- by the serial RS-232 link (PC parameterization software). The new address must be saved in the EEPROM and the positioner must be switched on again in order to get the new address operational;
- or by a Profibus class 2 master device. The address modification is only possible when the bus is not running. In this case, the address will be automatically saved in the positioner EEPROM and will be operational at the bus starting.

The identity number of the XtrapulsCD1-pm positioners under Profibus is 0x00C7.

### 4.2 - PROFIBUS HARDWARE ADDRESSING

In this operation mode, the XtrapulsCD1-pm address (1 to 125) is selected by means of the DIP micro-switches 1 to 7. DIP micro-switch 1 is the LSB and DIP micro-switch 7 is the MSB.

The selected hardware address is operational at the XtrapulsCD1-pm amplifier power on, regardless of the software address saved in the EEPROM.

The XtrapulsCD1-pm address can be modified by a Profibus class 2 master device. The address modification is only possible when the bus is not running. In this case, the address will be automatically saved in the positioner EEPROM. However, at the next XtrapulsCD1-pm power on, the selected hardware address is still operational.

The identity number of the XtrapulsCD1-pm positioners under Profibus is 0x00C7.

# Chapter 4 - Programming

## 1 – GENERAL DESCRIPTION

The XtrapulsCD1-pm amplifiers can get up to 128 pre-programmed sequences. Each sequence can be either :

- a homing sequence (HOME) or
- an absolute positioning sequence (ABSOLUTE) or
- an incremental positioning sequence (RELATIVE) or
- an electronic gearing sequence (GEARING) or
- a speed profile sequence (SPEED) or
- a torque control sequence (TORQUE).

The control sequences can be automatically linked up: as soon as a sequence is over, another one can be executed. This allows an easy solution of complex axis control applications by chaining several basic control sequences.

The XtrapulsCD1-pm amplifiers have got 8 programmable logic outputs (triggering at the sequences execution) and 8 programmable logic inputs allowing the control of a sequence start or stop. The logic inputs 1 to 6 are accessible on the X2 connector while the logic inputs 7 and 8 are virtual and can only be activated via PROFIBUS. The logic outputs 1 to 4 are connected on the X2 connector while the logic outputs 5 to 8 are virtual and can only be read via PROFIBUS.

The programming consists in initializing the sequence parameters with the desired values. A control sequence can then be selected by using the programmable logic inputs activation and its execution is started by using the START logic input. Any sequence execution can be stopped by using the STOP logic input.

In the Profibus operation mode, the positioner logic inputs (START, STOP, IN1 to IN6) can be activated either via the PROFIBUS or by using the hardware inputs on the X2 connector. The inputs source configuration is saved in the amplifier EEPROM. In the Profibus operation mode, all logic outputs (SEQ, POS, SPEED, OUT1 to OUT8) can be read via PROFIBUS.

## 2 – POSITIONER CONFIGURATION

### 2.1 – POSITION SCALING

**Position resolution:** defines the number of position increments for one motor revolution (or one motor pole pitch for a linear motor). The value range is between 128 and 65536 pts.

**Decimal:** number of decimals for the position display resolution (1, 2 or 3).

**Unit:** defines the unit used for the position display (maximum 4 characters).

**Example:** For a resolution of 4 mm / motor revolution, if the number of decimals = 3, the parameters are: Resolution = 4000, Decimal = 3, Unit = mm.

**Note:** When one of these parameters is changed, all position values in the positioner are displayed according to the new setting. The sequence set point values are also concerned.

**Deadband:** defines the deadband for the position controller. This parameter introduces a deadband at standstill around the position loop setpoint. When the position loop error is lower than this parameter value, the position loop proportional gain is set at 0. This parameter is reserved for specific applications with load backlashes and a high level of dry frictions. The deadband is deactivated when the parameter is set at 0.

**Enable second sensor feedback:** the selection of this command allows the use of the second position sensor (encoder or resolver) for closing the drive position loop. When this command is not selected, the drive position loop is using the motor position sensor (resolver or encoder) for feedback.

## 2.2 – POSITION LIMIT AND SAFETY

**Following error threshold:** defines the following error triggering threshold. It is important to correctly adjust this value in order to get a good protection. It can be adjusted like follows:

- 1 - Make the motor rotate with the required operation cycles and measure the maximum following error threshold:
  - either by means of the oscilloscope of the parameterization software,
  - or by reducing the following error threshold value until the fault is triggered,
- 2 - Then set the following error threshold at this value plus a margin of 30 to 50 %.

Example: Adjustment of the following error threshold on an axis with:

Position resolution = 5000.

Maximum following error measured by oscilloscope = 164.

The threshold is set at 246 (margin = 50 %).

Note: In the PC parameterization software, if the number of decimals is set at 3, the value that must be entered is 0,246.

**Following error detection mode:** defines the mode of operation of the axis following error protection.

When **Absolute** is selected, the following error protection is operating as described below.

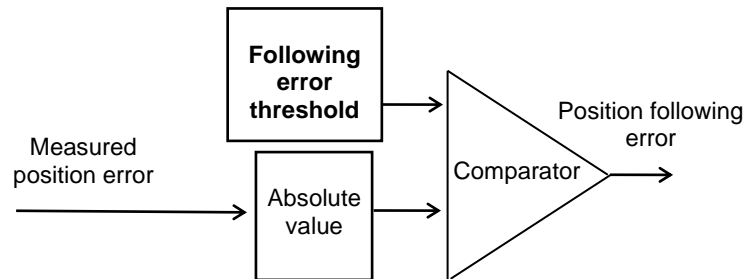

The measured position error value is continuously compared with the the **following error threshold** parameter value. When the measured position error is exceeding the **following error threshold**, the position following error is released. This configuration is used for applications requiring the smallest possible following error.

When **Relative to dynamic model** is selected, the following error protection is operating as described below.

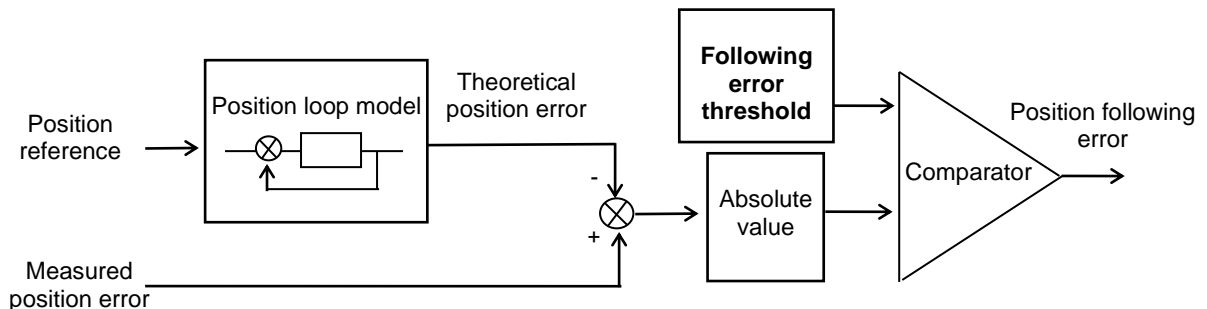

The measured position error value is continuously compared with the theoretical position error given by the position loop model. When the difference is exceeding the **following error threshold**, the position following error is released. In this configuration, when the position servo loop is adjusted to get the motor position continuously lagging the reference position (applications for positioning without overshoot and with a large following error value), any small anomaly in the actuator behaviour can be detected.

**Software position limits + and -:** this function is only active if the HOME sequence has been previously executed. When the motor passes the software limit position value, it is stopped with a controlled braking. The deceleration ramp value is given by the jog deceleration time.

## 2.3 – MANUAL MOVEMENTS

There are 2 types of manual motion:

- manual positioning: moving of the motor until a given position via the serial link.
- manual jog: continuous movement when the JOG command is activated.  
(JOG+ for a movement in the positive direction and JOG- for a movement in the negative direction)

The motion profile parameters are:

- motion speed,
- acceleration time,
- deceleration time.

The parameters **acceleration time** and **deceleration time** define the time with regard to the **maximum speed** parameter value. When the **motion speed** is lower than the maximum speed, the trajectory acceleration and deceleration times are proportionally reduced.

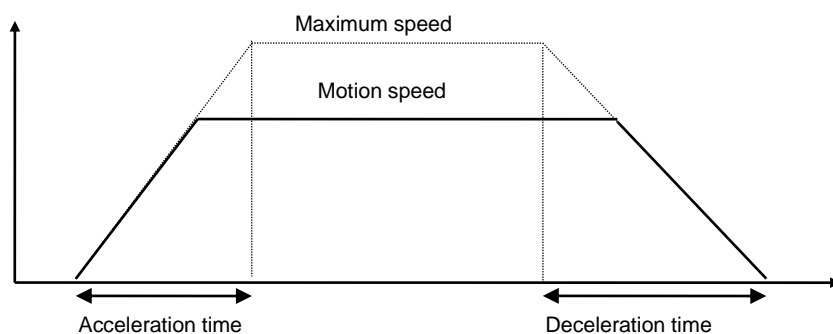

**Remark** : The JOG deceleration time parameter value is also used when the STOP input is activated.

## 2.4 – BRAKE CONTROL AND AMPLIFIER DISABLING

**Brake ON delay**: defines the time between the brake activation and the amplifier disabling according to the following timing:

- brake ON (contact open),
- delay time,
- amplifier disabled.

The brake ON delay value must be higher than the brake response time.

**Brake OFF delay**: defines the time between the amplifier enabling and the brake desactivation according to the following timing:

- amplifier enabling,
- delay time,
- brake OFF (contact closed).

The brake off delay value must be higher than the amplifier servo loop response time.

**Note**: The brake ON and OFF delays are not valid for the stand-alone operation mode.

**ENABLE input desactivation and fault reaction** defines the amplifier behaviour when the ENABLE input is desactivated or when an amplifier fault is triggered:

- When **Switch off** is selected, the amplifier is immediately disabled and the motor is freewheeling on ENABLE input desactivation or on a fault reaction.
- When **Stop with current limit** is selected, the motor is first slowed down and then the amplifier disabled on ENABLE input desactivation or a fault reaction.

**Stop current limit** defines the current limitation value when the motor is slowed down on ENABLE input desactivation or a fault reaction. This current limit value is also used for the motor slow-down when the hardware limit switches are activated.

**Remark**: The motor slow down with current limit is only possible when the following faults are triggered: **Position following error**, **I<sup>2</sup>t**, **Motor overtemperature**, **Fieldbus error**. When the other amplifier faults are triggered, the motor cannot be slowed down with current limit and the amplifier is immediately disabled.

**Note**: When the stopping with current limit operation is executed on ENABLE input desactivation or on a fault reaction, the motor brake is activated at the end of the deceleration phase, when the motor is stopped.

## 2.5 – POSITIONING PROFILE

**Speed profile:** trapezoidal or S-curve shape selection.

**Profile limit:** when the **Constant time** profile limit mode is selected, for a small displacement, if the profile speed cannot be reached, the motor acceleration and deceleration are modified in order to get the same acceleration and deceleration times than the programmed profile. This selection allows a smooth positioning for small displacements, however the displacement time is increased.

When the **Constant slope** profile limit mode is selected, for a small programmed displacement, if the profile speed cannot be reached, the motor acceleration and deceleration are similar to the programmed acceleration and deceleration values of the profile. This selection allows a faster positioning for small displacements, however a position loop overshoot may occur.

**Enable speed limitation:** when this command is selected, the sequence speed values can be reduced according to the PNU 714 value (in the Profibus operation mode) or the analog input voltage value on the X2 connector, as shown below. The speed reduction is also applied for manual movements (Positioning and Jog).

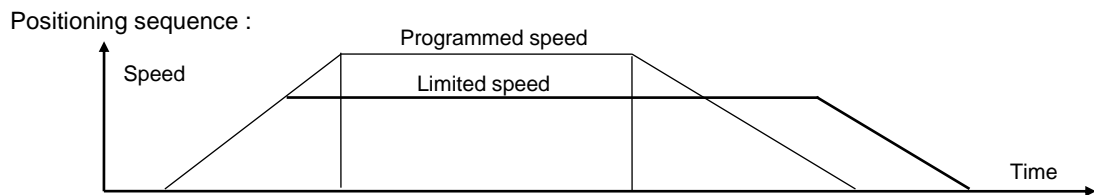

**Enable speed modulation:** when this command is selected, the programmed speed can be modified on-the-fly (during the sequence execution) for a positioning sequence (ABSOLUTE or RELATIVE). For the other sequences, the programmed speed is limited during the whole sequence execution according to the limitation value at the sequence start.

**Enable analog input:** when this command is selected, the sequence speed value is reduced according to the analog input voltage value on the X2 connector. The PNU 714 value is not considered.

**Analog input reversal:** when this command is selected, there is no limitation for 0 Volt on the analog input and full limitation is for 10 Volts. When this command is not selected, full limitation is for 0 Volt.

**Note 1:** The cut-off frequency value for the low-pass filter on the analog input is defined by the parameter **Analog Input low pass filter** in the **Controller parameters** window.

**Note 2:** The analog input must be selected by jumpers located on the amplifier connector board (see [XtrapulsCD1-pm Installation Guide](#), chapter 3, X2 connector).

## 2.6 – POSITION MODULO

**CLR input enable:** when activated (ticked off), it allows the use of the INDEX input for re-initializing the position counter: at the inactive-active transition of this signal, the **Clear position** parameter value will be loaded in the position counter.

**Reset counter/Modulo:** this function allows resetting the position counter when it reaches a pre-defined value. If the value is set at 0, this function is not activated.

**Forward:** when the **Reset counter/Modulo** function is activated, if **Forward** is selected (ticked off), the motor only runs in the positive direction for an absolute displacement lower than the value of the **Reset counter** parameter. When the **Reset counter/Modulo** function is activated, if **Forward** is not selected (not ticked off), for an absolute displacement lower than the value of the **Reset counter** parameter, the motor follows the shortest way (whichever the motor rotation direction).

## 2.7 – POSITIONER I/Os

**Profibus / Hardware inputs:** defines the configuration of the START, STOP, IN1 to IN6 inputs. In the stand-alone operation mode (without PROFIBUS), **Hardware** must be selected for all inputs.

**Inputs polarity:** defines the polarity of the optocoupled START, STOP, IN1 to IN8 inputs: a signal that is not ticked off corresponds to an active 24 V input.

**Sequence control:** The IN1 to IN7 inputs can be used for selecting sequences (ticked off in the PC software). There are maximum 128 sequences that can be selected this way by inputs IN1 to IN7 (in binary code). The other inputs can be used for the start condition.

**Output polarity:** defines the polarity of the optocoupled SEQ, POS, SPEED, OK, OUT1 to OUT8 outputs: a signal that is not ticked off in the PC software corresponds to an active 24 V output.

**Output pulse:** outputs OUT1 to OUT8 can be defined as pulse outputs (ticked off in the PC software) which duration is defined by the **output pulse duration** parameter (1 to 16000 ms).

**Minimum SEQ pulse:** when activated, this function defines the minimum duration of the SEQ output. This function is useful for the detection of a sequence with a short duration.

**InPos window:** when activated, this function defines the position window in which the **POS** output is activated: window = arrival position +/- programmed value. This parameter is only valid for a positioning sequence. If this function is not enabled, the **POS** output is activated at the end of the position trajectory regardless of the real position value.

**Digital CAM:** when activated, this function activates the logic output OUT1 when the motor passes an area defined by positions P1 and P2.

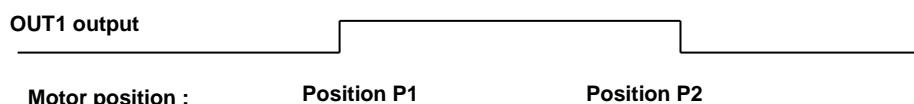

## 2.8 – SECOND SENSOR

**Position scaling factor (numerator / denominator):** this parameter allows the modification of the position resolution value on the second sensor input for electronic gearing or second sensor feedback applications.

**Reverse position:** when selected, this command allows reversing the counting direction on the second sensor input.

**Pulse interpolation:** this command is selected when the second sensor is a SinCos encoder type.

## 2.9 – PROFIBUS COMMUNICATION

**Address:** defines the software address (1 to 125) for the Profibus software addressing operation mode. This address is valid at the positioner power up only if all DIP micro-switches are on position OFF.

## 3 – EDITION OF A SEQUENCE

Parameters of a sequence:

<b>Type</b>	Defines the motion type. ABSOLUTE: absolute positioning. RELATIVE: relative positioning. GEARING: electronic gearing. HOME: axis homing. SPEED: speed profile. TORQUE: torque control.
<b>Position</b>	Position to be reached for an ABSOLUTE or RELATIVE positioning sequence. For a HOME sequence, this parameter indicates the value to be loaded in the position counter when the home position is found. When the <b>Position resolution</b> parameter is modified, all position values in the sequences are no more valid.
<b>Distance</b>	Axis travel distance for a GEARING sequence. This parameter is giving the output position of the gearing sequence. The gearing sequence output position = gearing sequence start position + distance parameter value. When the gearing sequence output position is reached, the motor is stopped according to the deceleration parameter value. If this parameter value is set at 0, then a sequence stop condition can be used for leaving the gearing sequence. When the <b>Position resolution</b> parameter is modified, all distance values in the sequences are not valid anymore.

<b>Speed</b>	Defines the motion speed in rpm. When the parameter <b>Max speed</b> is modified, all speed values in the sequences are scaled accordingly.
<b>Ratio</b>	Slave motor gearing ratio factor for a GEARING sequence. This parameter defines the master/slave gearing ratio factor in %. The slave motor gearing ratio value (defined by the <b>Position resolution</b> and the <b>Position scaling factor</b> parameter values) is multiplied by this factor during the GEARING sequence execution. The <b>Reverse gearing</b> selection allows reversing the slave motor displacement direction with regard to the master motor displacement.
<b>Torque</b>	For a TORQUE sequence, this parameter defines the torque set point in % of the <b>Maximum current</b> parameter value.
<b>Acceleration</b>	Defines the acceleration time in ms with regard to the <b>Maximum speed</b> parameter value. When the motion speed is lower than the maximum speed, the acceleration time is proportionally reduced. For a SPEED or TORQUE sequence, this parameter defines the acceleration time in ms from the initial speed at the sequence start up to the speed set point.
<b>Deceleration</b>	Defines the deceleration time in ms with regard to the <b>Maximum speed</b> parameter value. When the motion speed is lower than the maximum speed, the deceleration time is proportionally reduced. This parameter can be equal to 0 if a sequence linkage can be made without stopping the motor. For a SPEED sequence, this parameter defines the deceleration time in ms from the sequence speed set point up to 0. This parameter can be equal to 0 if a sequences linkage can be made without stopping the motor.
<b>Delay Time / TimeOut</b>	Defines the delay time in ms at the end of the positioning. For a SPEED sequence, this parameter defines the motor running time in ms at the speed set point value. If this parameter value exceeds 16000 ms, then a sequence stop condition can be used to leave the speed control sequence. For a TORQUE sequence, this parameter defines the torque holding time in ms when the torque set point value has been reached. If this parameter value exceeds 16000 ms, then a sequence stop condition can be used to leave the torque control sequence. For a HOME sequence, this parameter defines the time-out in seconds. The time-out is the time after which the positioner releases a Busy error if it does not find the home position. When this value is 0, the time-out protection is not activated.
<b>Next sequence</b>	Defines the number of the sequence to be executed after the current one.
<b>Counter</b>	Defines how many times the sequence must be executed. This counter is decremented each time a sequence is over.
<b>Counter link / Jump</b>	Defines the number of the sequence to be executed when the counter is not at 0.
<b>Logic outputs</b>	Defines the possible effect on the outputs.
<b>Triggering</b>	Defines the outputs triggering moment.
<b>Triggering position</b>	Defines the outputs triggering position.
<b>Start condition</b>	Defines the possible effect on the logic inputs. The <b>Stop</b> selection allows the use of the logic inputs as a sequence stop condition. A sequence stop condition is only valid for a SPEED or TORQUE sequence when the running time or the holding time value is higher than 1600 ms. For a GEARING sequence, the sequence stop condition is only valid if the distance value is set at 0. When <b>Stop</b> is deactivated, the logic inputs are used as a sequence start condition, whichever the sequence type.
<b>Home control</b>	For a HOME sequence, this parameter defines the amplifier configuration for the homing sequence execution.

### 3.1 - HOMING SEQUENCE

A homing sequence is defined by:

- the motion speed,
- the acceleration time,
- the deceleration time,

The parameter acceleration and deceleration times define the time with regard to the maximum speed parameter value. When the motion speed is lower than the maximum speed, the trajectory acceleration and deceleration times are proportionally reduced in order to maintain the same acceleration and deceleration values.

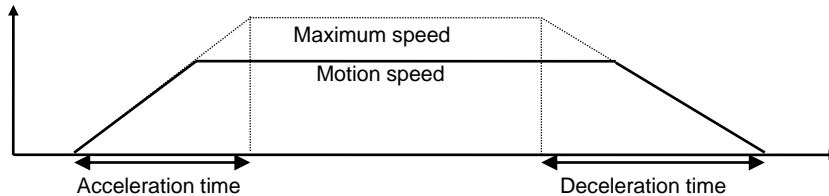

- a time out,
- a position reset value,
- the control (5 bits):

- Dir** Searching direction: 0 for the positive direction and 1 for the negative direction.
- Switch** Homing with switch detection.
- Zero** Homing with marker pulse detection.
- Home** This parameter gets back to the home position (motion reversal); otherwise the motor will be stopped after the braking.
- Reset** Load the position reset value in the position counter at the home position.

**Homing procedure diagram:**

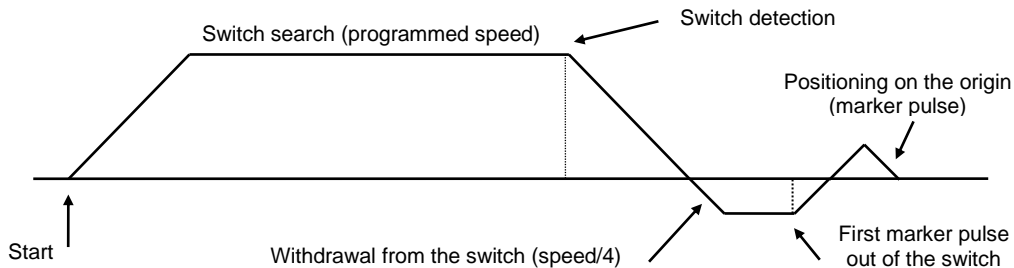

If Switch=1 and Zero=1 or Home=1, the speed can be reversed by the switch detection or by a limit switch.

In the configuration Switch=0 and Zero=1, if the limit switch in the searching direction is activated, at the homing sequence starting, the homing cannot be executed.

**Homing procedure diagram with switch only:**

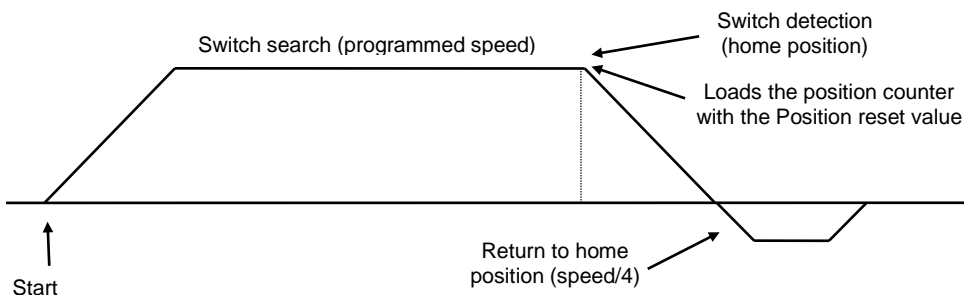

When sequence 0 contains a homing procedure at power on, no other sequence can be executed before sequence 0.



### 3.2 - POSITIONING SEQUENCE

A positioning sequence is defined by:

- the position to be reached (absolute or relative),
- the motion speed,
- the acceleration time,
- the deceleration time.

The upper limit value for the position set point (absolute or relative) is  $+ 2^{16} \times (\text{position resolution parameter value}) - 1$ .

The lower limit value for the position set point (absolute or relative) is  $- 2^{16} \times (\text{position resolution parameter value})$ .

The parameter acceleration and deceleration times define the time with regard to the maximum speed parameter value. When the motion speed is lower than the maximum speed, the trajectory acceleration and deceleration times are proportionally reduced in order to maintain the same acceleration and deceleration values.

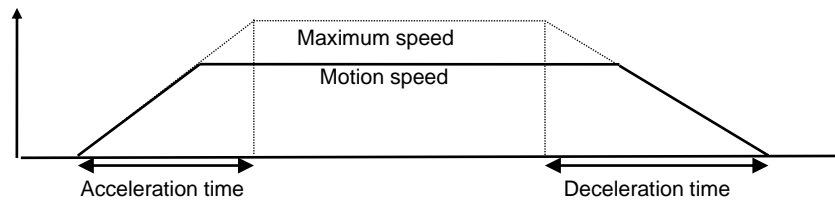

- a delay time at the end of the motion.

Linkage example of 2 positioning sequences without stopping (the deceleration ramp of the first sequence is 0):

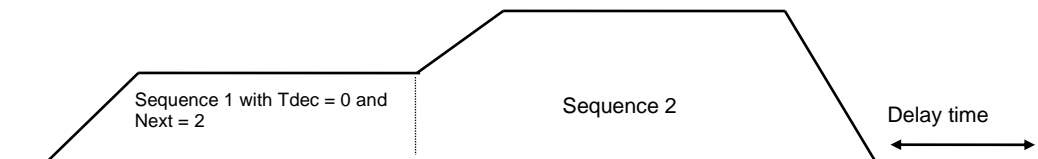

**Note:** For a small displacement, when the programmed motion speed value cannot be reached, the motion speed profile is modified according to the **Profile limit** parameter selection:

- When **Constant time** is selected, the trajectory acceleration and deceleration are reduced and the profile is calculated according to the programmed acceleration and deceleration time values. This selection allows a smooth positioning for small displacements, however the displacement time is increased.

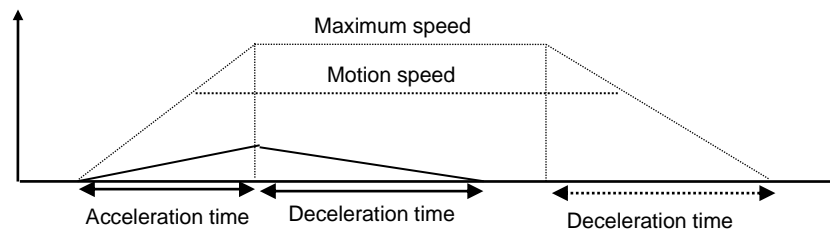

- When **Constant slope** is selected, the motor acceleration and deceleration are similar to the profile acceleration and deceleration programmed values. This selection allows a faster positioning for small displacements, however a position loop overshoot may occur.

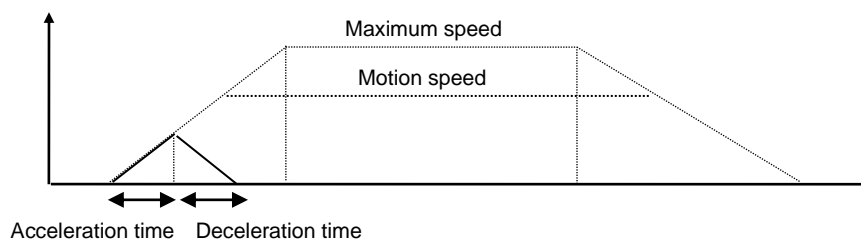

### 3.3 - SPEED SEQUENCE

A speed sequence is defined by:

- the speed set point,
- the running time,
- the acceleration time,
- the deceleration time.

When the running time exceeds 16000 ms, the stop condition can be used for stopping the sequence.

**Note:** The **Acceleration time** and **Deceleration time** parameters are the real acceleration and deceleration time values and not acceleration and deceleration ramps with regard to the **Maximum speed** value, as they are in a positioning sequence or a homing sequence.

The sequences linkage allows the creation of speed profiles.

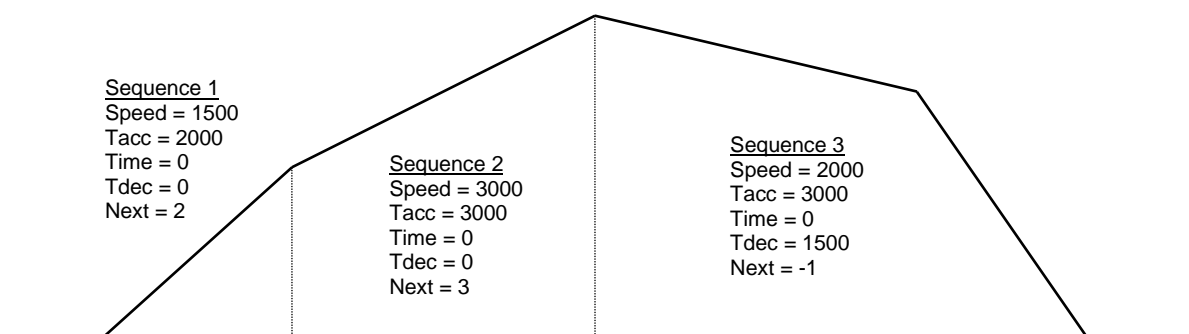

**Note:** "Next" = -1 corresponds to an empty field in the PC software.

### 3.4 - TORQUE SEQUENCE

A torque sequence is defined by:

- the speed set point,
- the acceleration time,
- the torque set point,
- the torque holding time (delay).

Torque sequence execution:

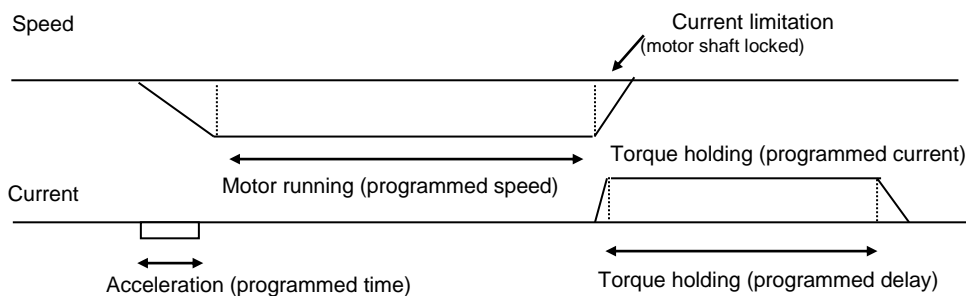

In the torque control sequence, the motor is running at the speed set point value until the current rises up to the limit value defined in percentage of the **Maximum current** parameter value. The motor running direction depends on the sign of the speed set point. When the current limitation is reached, the amplifier is holding this current during the time interval defined by the **Delay time** parameter. If the **Delay time** exceeds 16000 ms, the torque holding time is infinite. In this case the sequence can be left by a stop condition.

The **Acceleration time** parameter is the real acceleration time value and not an acceleration ramp with regard to the **Maximum speed** value, as it is in a positioning sequence or a homing sequence.

The **Hold** triggering condition allows the outputs activation when the current limit is reached.

### 3.5 - GEARING SEQUENCE

A gearing sequence is defined by:

- the gearing distance,
- the gearing ratio factor,
- the gearing direction,
- the acceleration time,
- the deceleration time.

At the start of the sequence, the motor speed is ramping according to the acceleration parameter value. When the motor speed value reaches the second sensor velocity, the motor position is locked in phase and frequency with the second sensor position according to the gearing ratio value. The **Gearing ratio** is defined by the **Position resolution** and the **Position scaling factor** parameter values (see chapter 2 Commissioning, section 14.2). During the sequence execution, this value is multiplied by the sequence gearing ratio factor. The **Reverse gearing** selection allows reversing the motor displacement direction with regard to the second sensor displacement. The servo motor (slave) is following the second sensor position (master) up to the output position value.

The output position value is equal to the gearing sequence start position + the distance parameter value. When the output position is reached, the motor is stopped according to the deceleration parameter value. If the deceleration parameter value is set at 0, the next sequence is immediately executed.

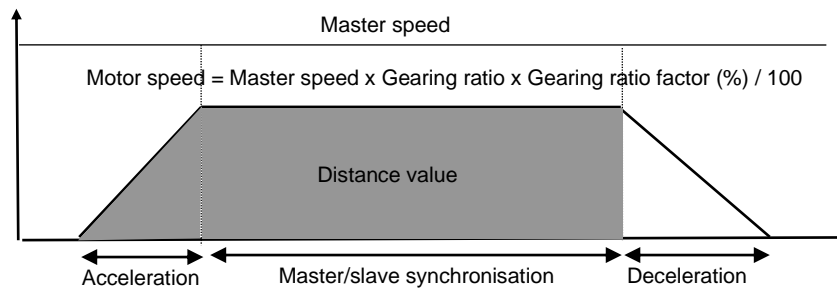

The acceleration and deceleration times parameters define the time with regard to the **Maximum Speed** parameter value as in a positioning sequence or a homing sequence.

When the distance value is set at 0, the stop condition can be used for stopping the sequence.

### 3.6 - SEQUENCES CHAINING

#### 3.6.1 – COUNTER LOOP

The sequences linkage is controlled by the “Next sequence”, “Counter” and “Jump” parameters.

Application example:

Sequence 1:    Next sequence = 2  
                  Counter = 0  
                  Jump = -1

Sequence 2:    Next sequence = 3  
                  Counter = 2  
                  Jump = 1

Sequence 3:    Next sequence = -1  
                  Counter = 0  
                  Jump = -1

Note: "Next" = -1 or "Jump" = -1 corresponds to an empty field in the PC software.

If the execution is starting at sequence 1, the programme will be the following:

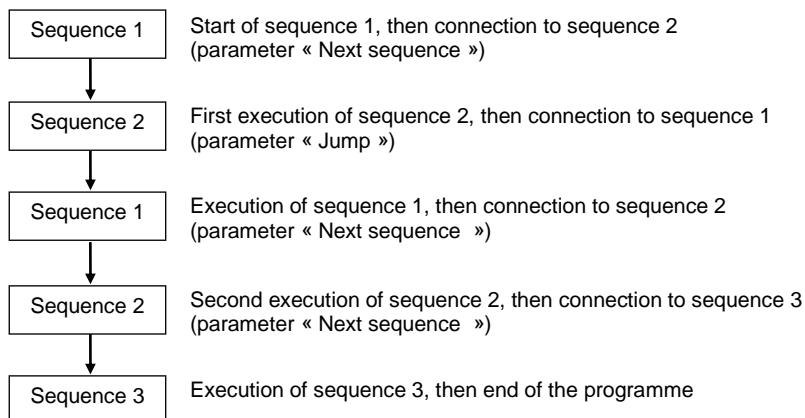

### 3.6.2 – CONDITIONAL JUMP

The conditional jump is controlled by using the “**Start condition**” and the “**Next sequence**”, “**Counter**” and “**Jump**” parameters.

Application example:

- Sequence 1: Next sequence = 2  
Counter = 0  
Jump = -1
- Sequence 2: Next sequence = 3  
Counter = 0  
Jump = 4  
Start condition = Logic input 8 activated
- Sequence 3: Next sequence = -1  
Counter = 0  
Jump = -1
- Sequence 4: Next sequence = -1  
Counter = 0  
Jump = -1

Note: "Next" = -1 or "Jump" = -1 correspond to an empty field in the PC software.

If the execution is starting at sequence 1 and logic input 8 is activated, the programme will be the following:

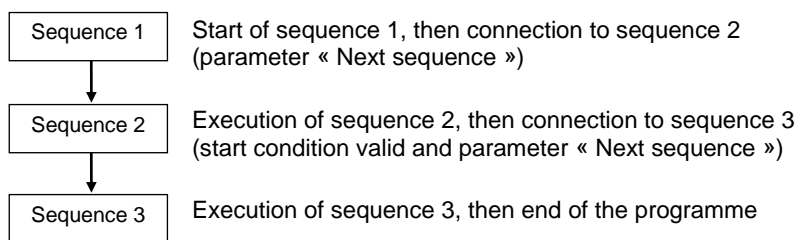

If the execution is starting at sequence 1 and logic input 8 is deactivated, the programme will be the following:

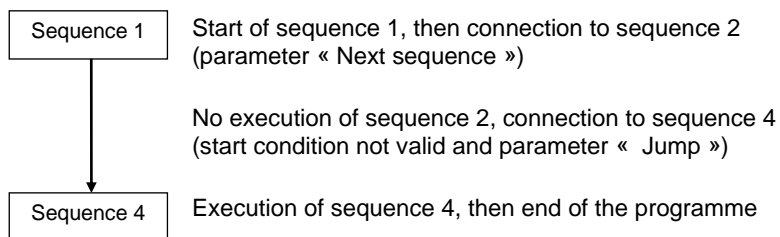

### 3.7 - PROGRAMMABLE OUTPUTS

#### Outputs

The action on the 8 logic outputs can be defined as follows:

- do not modify the output status,
- set the output at 1,
- set the output at 0,
- reverse the output (toggle).

#### Triggering

The outputs triggering moment can be defined, during a motion, according to one of the 5 different ways described below:

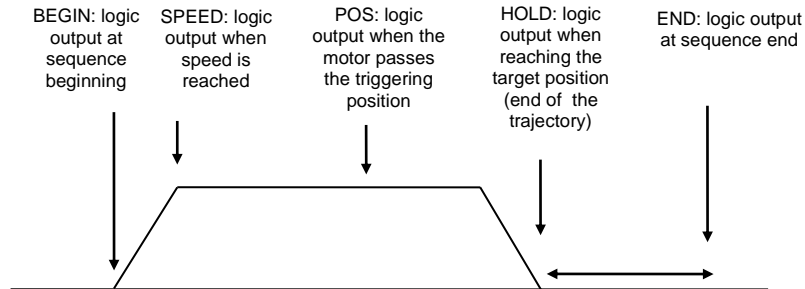

In a homing sequence, the outputs only trigger at the end of the sequence.  
 In a speed sequence, the HOLD and POS triggerings are not possible.  
 In a torque sequence, the POS triggering is not possible.

The outputs can be configured as pulse outputs with a preset duration. This function only concerns the outputs set at 1 or toggle.

#### Triggering position:

Defines the position where the logic output must be triggered when it is programmed in POS triggering.

### 3.8 - PROGRAMMABLE INPUTS

#### Start condition

The possible effect on the 8 logic inputs can be selected as follows:

- ignore the input status,
- trigger on positive level (input activated),
- trigger on negative level (input deactivated).

The inputs can be used either as a sequence start condition or as a sequence stop condition. When **Stop** is deactivated, the logic inputs are used as a sequence start condition for any sequence type. The **Stop** selection allows the use of the logic inputs as a sequence stop condition. A sequence stop condition is only valid for a SPEED or TORQUE sequence when the delay time value is higher than 1600 ms.

**NOTE** : The programmable inputs configured for the sequence selection cannot be used for a start condition.

## 4 - PROGRAMME EXECUTION

The execution of a sequence can be made either:

- via the START logic input: this input triggers the execution of the sequence which number is defined by inputs IN1 to IN7 (in natural binary code),
- or via the serial link. The PC software allows the execution of any sequence number.
- or via PROFIBUS when bit 6 of the control word is toggled (see manual [XtrapulsCD1-pm – PROFIBUS Communication Profile](#))

**NOTE** : A sequence execution requires the **OK** output to be active.

## 5 - SPEED LIMITATION

The sequence speed value (except for the GEARING sequence) can be reduced according to the analog input voltage value on the X2 connector or the PNU 714 value (in PROFIBUS operation mode). This speed reduction is also applied on manual movements (Positioning and Jog).

This functionality can be enabled or disabled by the selection of the **Enable speed limitation** command. For the positioning sequences (ABSOLUTE or RELATIVE), the programmed speed can be continuously modified during the sequence execution according to the limitation value if **Enable speed modulation** is selected. For the HOME, SPEED and TORQUE sequences, the programmed speed is limited over the whole sequence execution according to the limitation value at the sequence start.

When **Enable analog input** is selected, the limitation is provided by the analog input voltage value. If **Enable analog input** command is not selected, the limitation is provided by the PNU 714 value (in PROFIBUS operation mode). The speed reduction can be proportional or inversely proportional to the analog input voltage value according to the **Analog input reversal** command.

Note: The analog input must be selected by jumpers located on the amplifier connector board (see [XtrapulsCD1-pm Installation Guide](#), chapter 3, X2 connector).

## Chapter 5 – PROFIBUS communication

For the commissioning of the **PROFIBUS** communication, please see manual "[XtrapulsCD1pm – PROFIBUS Communication Profile](#)".

# Chapter 6 – Troubleshooting

## 1 - DIAGNOSTICS







A fault diagnostic can be made:

- visually: front panel LED display.
- by serial link: clear fault display by the PC parameterization software.
- by Profibus link: error code reading.

At an error triggering, the positioner is disabled.

### 1.1 - XtrapulsCD1-pm FAULT LEDs

Six display LEDs are available on the XtrapulsCD1-pm front panel:

(green) ON   SYS (yellow)  
 (red) ERROR   AP (red)  
 (green) BUS   BUSY (yellow)

### 1.2 – FAULT RESET

The reset of a stored fault can be made:

- via the fault RESET input of X4, pin 8,
- via the serial link,
- by the control issued from Profibus,
- by switching off the positioner power supply.

## 2 – FAULT FINDING

### 2.1 – SYSTEM FAULT

If the "SYS" LED is lit at power on, the logic board is defective.

- Check that the **BUS**, **BUSY**, **AP** and **ERROR** leds are synchronously blinking. In this case, load the amplifier firmware via the serial link by means of the **CD1updater software**.
- Check for no conducting dust that may involve short-circuits on the amplifier logic board.

### 2.2 – NON STORED FAULTS

#### 2.2.1 – BUS FAULT (Profibus)

This fault is only displayed when the Profibus communication is interrupted.  
 The fault is cancelled as soon as the communication is restored.

#### 2.2.2 - "UNDERVOLT." FAULT

- If the fault occurs at the positioner commissioning:  
 \* Check that the power supply is on.

### 2.3 – STORED FAULTS

If a fault occurs on the positioner, it can generate the detection of several other faults which are only a consequence of the initial one. In order to make diagnostic and maintenance easier, the faults are displayed and processed with the priority described below. For safety reasons, the power must be turned off for the cancelling of some faults that requires the handling of the positioner. In this case, the RESET is automatic when power is turned on again. If power is not turned off, do not forget to make a RESET immediately after the fault is cancelled.



### 2.3.1 - "BUSY" FAULT

- If the BUSY fault is continuously displayed after powering the positioner, the **AUTOTEST** procedure has failed and the positioner is not ready for operation. **Check that the power voltage is not on before the 24 V auxiliary supply.**
- If the BUSY fault is continuously displayed after the motor **PHASING** procedure at power up (**Incremental encoder without HES** configuration), the procedure has failed because of an external cause and the calculated phase value is wrong.  
Check that the **Motor encoder resolution** parameter value is correct.  
Check that the **Motor parameters (Pole pairs and Phase order)** values are correct.  
Check that the **ENABLE** input is activated.  
Check that the limit switches inputs are not activated.  
Check that the motor is not locked and the shaft movement is free during the procedure.
- If the BUSY fault is continuously displayed after the execution of the **AUTOPHASING** function, the procedure has failed because of an external cause and the calculated parameters are wrong. Check that the **ENABLE** input is actually activated. Then check that the motor is unloaded and the shaft movement is free during the procedure.
- If the BUSY fault is continuously displayed after the execution of the **AUTOTUNING** function, the procedure has failed because of an external cause and the calculated parameters are wrong. Check that the **ENABLE** input is activated and the limit switches are not activated. Then check that the motor is unloaded and the shaft movement free during the procedure.
- If the BUSY fault is continuously displayed after the execution of the **COGGING TORQUE ACQUISITION** procedure, the procedure has failed because of an external cause and the cogging torque acquisition is not valid.  
Check that the **ENABLE** input is activated.  
Check that the limit switch inputs are not activated.  
Check that the encoder is providing one marker pulse per motor revolution.  
Check that the motor is unloaded and the shaft movement is free during the procedure.  
Check that the motor current value corresponding to the cogging torque effect is lower than 5 % of the amplifier current rating.
- This fault may also occur during a homing procedure which "time out" is too low.

### 2.3.2 - "EEPROM" FAULT

- Check for the presence of the EEPROM and check its correct orientation.
- If the fault remains, the EEPROM is not correctly initialized (**CHECKSUM**) or is not complying with the positioner software.
- This fault may occur if the motor is enabled during a parameter saving or during a sequences transfer between PC and positioner.
- To cancel this fault, if it is:
  - \* due to the parameters, renew the positioner parameterization and the parameter saving,
  - \* due to the sequences, send the sequences to the positioner again.

### 2.3.3 - "°C MOTOR" FAULT

If the error occurs when commissioning the amplifier:

- Check the **CTN/CTP** parameterization, the **Triggering threshold** and the **Warning threshold**.
- Check the wiring of the thermal sensor on the amplifier resolver or encoder connector.

If the error occurs during the operation:

- Check that the triggering threshold is complying with the manufacturer's specifications of the sensor.
- Check the motor temperature and look for the reason of this overheating (mechanical shaft overload, duty cycle too high, ...).

### 2.3.4 - "POWER STAGE" FAULT

The POWER STAGE fault groups all faults issued from the power board:

- Power supply overvoltage.
- Phase/ground short-circuit.
- Phase/phase short-circuit.
- Fan.
- Power stage short-circuit.
- Power stage overtemperature (on XtrapulsCD1-pm-400/l only).
- PWM control error.
- Power stage supply.
- Braking system error: transistor short-circuit or cycle too high.

The VISUAL DRIVE SETUP software allows the identification of the "Power stage" fault.

If the fault occurs when starting the amplifier:

- Check the AC voltage on the L1 - L2 - L3 inputs of the X9 connector.

**CD1-pm-230/l amplifier** : 196 VAC < VAC < 253 VAC **CD1-pm-400/l amplifier** : 340 VAC < VAC < 528 VAC

If the fault occurs during the operation:

- Check the braking system during the motor deceleration phases.
- Check the sizing of the braking resistor with regard to the motor deceleration phases.
- Check that the current cycle corresponds to the current table ([see manual XtrapulsCD1-pm Installation, Chapter 2, section 1](#)).
- Check for no short-circuit in the motor wiring and at the motor terminals.
- Check for no short-circuit between a motor phase and the ground.

### 2.3.5 - "RESOLVER" FAULT

- Check the resolver connection on the amplifier X1 connector according to the connector description.
- Check for the correct resolver type with regard to the amplifier specifications.
- Check the connections between the resolver and the amplifier.

### 2.3.6 - "R.D.C." FAULT

If the failure occurs when starting the amplifier:

- Check for the correct resolver type with regard to the amplifier specifications.

If the failure occurs during the operation:

- Check that the connections between the resolver and the amplifier are complying with the shield wiring recommendations.

### 2.3.7 - "ENCODER" FAULT

Check the encoder supply connection on the amplifier connector X3.

Check the encoder A channel and B channel connections on the amplifier connector X3.

**Note:** In the **Incremental encoder without HES** configuration, the motor **Phasing** procedure must be carried out again after an **Encoder** fault release.

### 2.3.8 - "COUNTING" FAULT

Check the marker pulse connection on the amplifier connector X3. If the motor encoder does not provide a marker pulse channel output, the amplifier marker pulse channel must be disabled in order to cancel the **Counting** fault. The amplifier marker pulse channel can be disabled by means of the parameter **Zero mark pitch** set at 0.



When the amplifier marker pulse channel has been disabled, the encoder counting protection is no more active. In this case, encoder pulse noise may involve uncontrolled motor movements that may be dangerous for operator and machine.

For the **TTL incremental encoder** configuration:

- Check for the correct encoder supply voltage value.
- Check for the correct encoder-amplifier-motor ground and shield connections with regard to the recommendations in [chapter 4 of the XtrapulsCD1-pm Installation Guide](#).
- Check for the correct encoder A channel, B channel and Z marker signal waveforms.

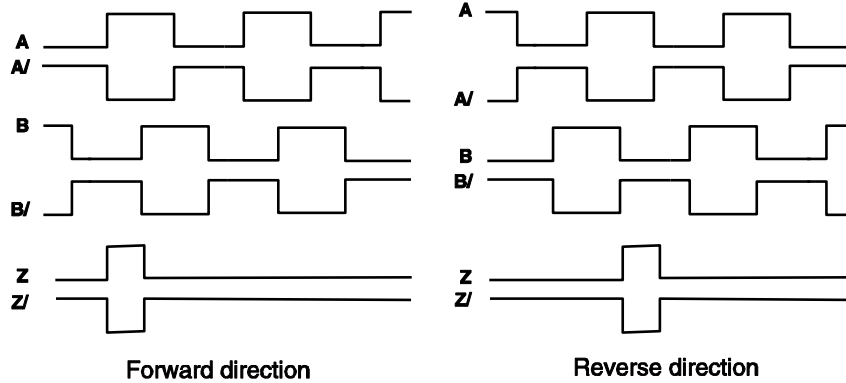

- Check that the following conditions are answered for taking into account the maximum value of the encoder pulse frequency at the maximum motor speed value :  
 Max. motor speed (rpm) <math>< 60 \times 10^6 / \text{Number of encoder pulses per revolution}</math>  
 Max. motor speed (rpm) <math>< 60 \times \text{Encoder pulse frequency limit (Hz)} / \text{Number of encoder pulses per revolution}</math>
- Check that the **Motor encoder resolution** and the **Zero mark pitch** parameter values are correct.
- Check that the number of encoder pulses between two successive Z marker pulses is equal to the **Motor encoder resolution** value multiplied by the **Zero mark pitch** parameter value. If this condition is not fulfilled, the encoder counting protection must be disabled in order to cancel the **Counting** fault. The encoder counting protection can be disabled by means of the parameter **Zero mark pitch** set at 0.
- For a linear motor with only one marker pulse over the whole motor travelling range, the parameter **Zero mark pitch** must be set at 15. In this case the encoder counting protection is checking that the measured encoder position has always got the same value when the marker pulse is activated (no position measurement drift).



When the encoder counting protection has been disabled, the amplifier is only checking that the encoder pulses frequency is lower than 1.5 times the maximum encoder frequency. The maximum encoder frequency is calculated into the amplifier according to the **Motor encoder resolution** parameter value and the **Maximum speed** parameter value. In this case, encoder pulse noise at a frequency lower than 1.5 times the maximum encoder frequency may involve uncontrolled motor movements that may be dangerous for operator and machine.

**Note:** In the **TTL incremental encoder** configuration **without HES**, the motor **Phasing** procedure must be executed again after a **Counting** fault release.

For the **Sin/Cos encoder** configuration:

- Check for the correct encoder supply voltage value
- Check for the correct encoder-amplifier-motor ground and shield connections with regard to the recommendations of [chapter 4 in the XtrapulsCD1-pm Installation Guide](#).
- Check for the correct encoder A channel, B channel and R reference signal waveforms.

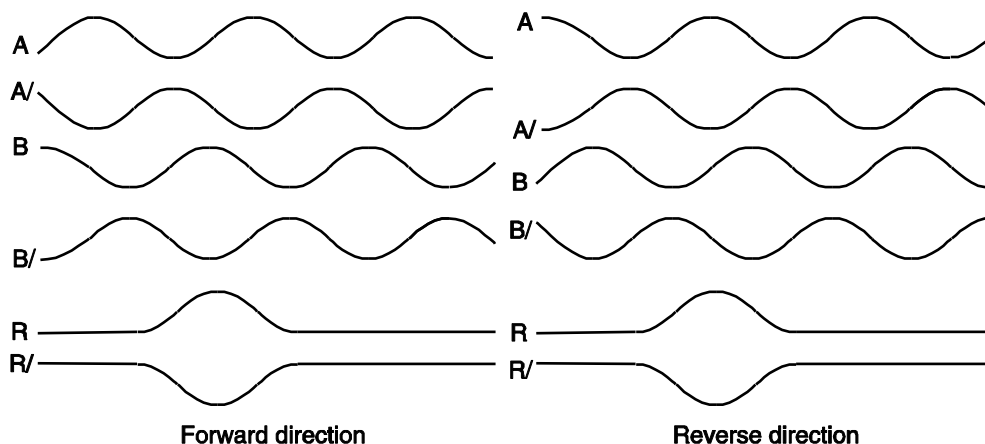

- Check that the **Motor encoder resolution** and the **Zero mark pitch** parameter values are correct.
- Check that the number of encoder pulses between two successive R reference signals is equal to the **Motor encoder resolution** value multiplied by the **Zero mark pitch** parameter value. If this condition is not fulfilled, the encoder counting protection must be disabled in order to cancel the **Counting** fault. The encoder counting protection can be disabled by means of the parameter **Zero mark pitch** set at 0.
- For a linear motor with only one R reference signal over the entire motor travelling range, the **Zero mark pitch** parameter must be set at 15. In this case the encoder counting protection is checking that the encoder measured position has always got the same value when the R reference signal is activated (no position measurement drift).



When the encoder counting protection has been disabled, the amplifier is only checking that the encoder pulses frequency is lower than 1.5 times the maximum encoder frequency. The maximum encoder frequency is calculated into the amplifier according to the **Motor encoder resolution** parameter value and the **Maximum speed** parameter value. In this case, encoder pulse noise at a frequency lower than 1.5 times the maximum encoder frequency may involve uncontrolled motor movements that may be dangerous for operator and machine.

**Note:** In the **Sin/Cos encoder without HES** configuration, the motor **Phasing** procedure must be executed again after a **Counting** fault release.

### 2.3.9 - "HES" FAULT

**For the Incremental encoder & HES configuration:**

- Check that the HES are correctly wired on the amplifier X3 connector (with 60° type HES you must check the various wiring combinations to find the right wiring order).
- Check for the correct HES supply voltage value.
- Check for the correct **Motor encoder resolution** parameter value.
- Check that the HES-amplifier-motor ground connections and shield answer the requirements of [chapter 4 of the XtrapulsCD1-pm Installation Guide](#).

**For the Absolute single-turn Sin/Cos encoder configuration:**

- Check that the Sin/Cos encoder commutation channels are correctly wired on the amplifier X3 connector.
- Check for the correct Sin/Cos encoder supply voltage value.
- Check for the correct Sin/Cos encoder C channel and D channel signal amplitude value.
- Check that the **Motor encoder resolution** parameter value is correct.
- Check that the encoder-amplifier-motor ground connections and shield answer the requirements of [chapter 4 of the XtrapulsCD1-pm Installation Guide](#).

### 2.3.10 - " POSITION FOLLOWING " FAULT

If the error occurs during the axis motion:

- Check the position loop adjustment.
- Check the coherence of the **Static threshold** parameter with regard to the motion cycle.

### 2.3.11 - "CURRENT OFFSET " FAULT

If the "Current offset" error occurs at power on, this means that the offset compensation procedure has failed and the amplifier is not ready for operation. This error cannot be cancelled.

### 2.3.12 - " INIT 400V " FAULT

If the "INIT 400V" error occurs on a XtrapulsCD1-pm **400**/I amplifier, at power on:

- Check that the amplifier powering has been correctly made. This error cannot be cancelled.

### 2.3.13 - "I2t" FAULT

- Check the rated current value required from the amplifier with regard to the current table.
- Check the amplifier rated current value defined in the **Rated current** parameter with regard to the current required for the operation cycle.

## 3 – OPERATING PROBLEMS

### 3.1 – MOTOR DOES NOT MOVE

- Check that the positioner is on.
- Check that the power supply is on.
- Check the motor connection.
- Check the logic wiring of the signals FC+, FC- and ENABLE.
- Check that the positioner is enabled.

### 3.2 – MOTOR SUPPLIED BUT NO TORQUE

- Check that the **Maximum current** and **Rated current** parameters have no zero value.

### 3.3 – SHAFT LOCKED, ERATIC OSCILLATIONS OR ROTATION AT MAXIMUM SPEED

- Check the resolver or encoder wiring on the amplifier connector as well as the mechanical fastening of the position feedback sensor on the motor.
- Check for the correct motor selection in the **MOTOR LIST** module.
- Check the value of the motor parameters (number of pole pairs, resolver wiring, motor phase) and renew the **AUTO-PHASING** command, with unloaded motor, if required

### 3.4 – DISCONTINUOUS MOTOR ROTATION WITH ZERO TORQUE POSITIONS

- Check the connection of the three phase cables between motor and positioner.

### 3.5 – LOUD CRACKLING NOISE IN THE MOTOR AT STANDSTILL

- Check that the Motor-Positioner-Controller ground connections comply with the recommendations
- Check the rigidity of the mechanical transmission chain between motor and load (backlashes and elasticity in the gears and couplings).
- Start a new **Autotuning** procedure by selecting a lower bandwidth than the initial one.

### 3.6 – LOUD NOISE IN THE MOTOR AT STANDSTILL AND WHEN RUNNING

- Check the rigidity of the mechanical transmission chain between motor and load (backlash and elasticity in the gearboxes and couplings).
- Execute the **AUTOTUNING** command again by choosing a lower bandwidth (**Medium** or **Low**).

### 3.7 – SEQUENCE NOT EXECUTED

In "operation enabled" status, the motor does not move at a sequence start in following cases:

- If, after power on, the operator wants to start a positioning sequence whereas sequence 0 is a homing sequence that is not yet executed.
- A start condition has been defined for this sequence and is not fulfilled.
- One or two limit switches are activated.

## 4 - SERVICE AND MAINTENANCE

When exchanging a positioner on a machine, proceed as follows:

- Check that the new positioner has got the same voltage and current ratings as well as the same hardware configuration as the one to be replaced.
- Reload and save the parameters and the sequences of the old amplifier via the serial link or the **PROFIBUS** interface.

The new positioner is now ready for operation.

## Appendix

### 1 - SERVO CONTROLLER STRUCTURE

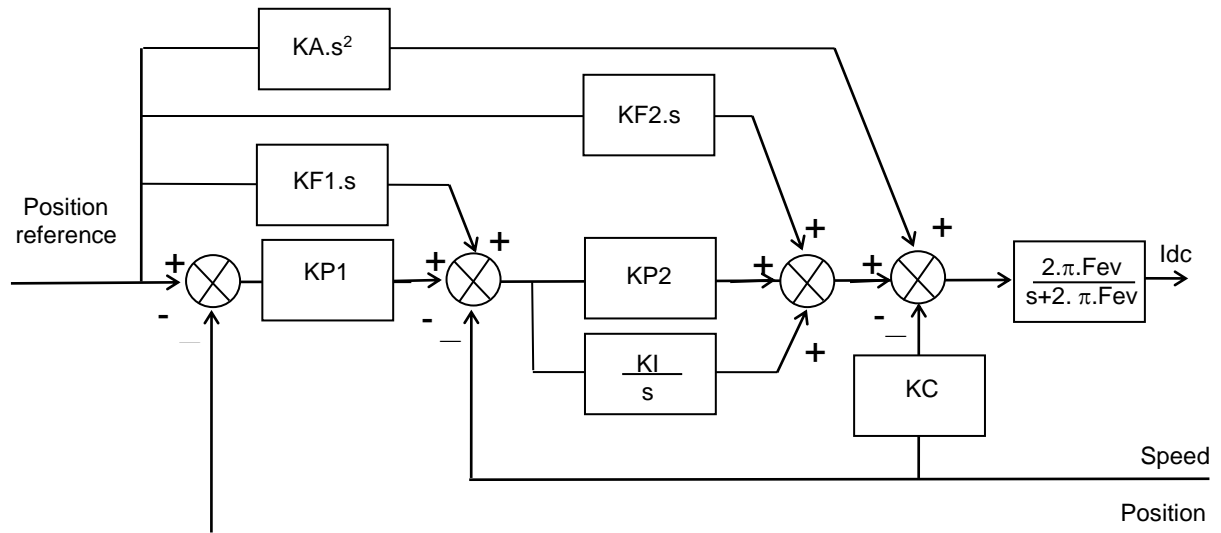

**Speed error low-pass filter (Fev):** defines the cut-off frequency at -3dB of the first order filter which acts on the current command ( $I_{dc}$ ). This value is calculated by the amplifier during the auto-tuning procedure and depends on the selected bandwidth and the selected filter type.

**Proportional speed gain (KP2):** defines the proportional gain of the controller which acts on the speed error. Its value is calculated by the amplifier during the auto-tuning procedure. It can then be modified by the user if required.

**Integral speed gain (KI):** defines the integral gain of the controller which acts on the speed error. Its value is calculated by the amplifier during the auto-tuning procedure. It can then be modified by the user if required.

**Damping gain (KC):** defines the proportional gain of the controller which acts only on the speed feedback. Its value is calculated by the amplifier during the auto-tuning procedure. It can then be modified by the user if required.

**Proportional position gain(KP1):** defines the proportional gain of the controller which acts on the position error. Its value is calculated by the amplifier during the auto-tuning procedure. It can then be modified by the user if required.

**Feedforward speed 1 gain(KF1):** defines the feedforward speed amplitude corresponding to the speed input command. This term allows reducing the following error during the motor acceleration and deceleration phases. Its value is set at 1 after the auto-tuning procedure if a following error as small as possible is required. It can then be modified by the user if required.

**Feedforward speed 2 gain(KF2):** defines the feedforward speed amplitude corresponding to the viscous frictions. This term allows reducing the viscous friction effect during the motor acceleration and deceleration phases. The gain value is equal to the damping gain value + the viscous friction compensation a term. After the auto-tuning procedure, the feedforward speed 2 gain is set equal to the damping gain value if a following error as small as possible is required. The viscous friction compensation term can be calculated by measuring the current/speed ratio at various motor speed values.

**Feedforward acceleration gain(KA):** defines the feedforward acceleration amplitude corresponding to the acceleration input command. This term allows reducing the following error during the motor acceleration and deceleration phases. Its value is calculated by the amplifier during the auto-tuning procedure if a following error as small as possible is required. It can then be modified by the user if required.

The auto-tuning procedure identifies the characteristics of motor and load and calculates the controller gains. During the procedure, various choices are available to the user.

The choice of the time interval for speed measurement (speed measurement filter) allows selecting the speed measurement resolution value according to the position sensor resolution value:

$$\text{speed resolution (rpm)} = 60000 / \text{position sensor resolution (ppr)} / \text{time interval (ms)}.$$

The higher the time interval value, the better the resolution, but also the lower the servo loop gains because of the increased speed measurement delay.

The choice of the anti-resonance filter is necessary in case of loud noise in the motor due to the motor/load coupling elasticity.

The choice of the maximum stiffness filter allows the maximum stiffness on the motor shaft with regard to the torque disturbances. However, this choice is only possible without any resonance due to the motor/load coupling elasticity.

The choice of the speed loop bandwidth defines the cut-off frequency value of the closed loop frequency response (Low = 50 Hz, Medium = 75 Hz, High = 100 Hz).

The choice "**minimum following error**" allows an accurate following of the position reference value during the entire motor displacement. In this case, all feedforward gain values are calculated.

The choice "**minimum position overshoot**" allows a motor positioning without any overshoot of the target position. In this case, all the feedforward gain values are set at 0, and the motor position is lagging with regard to the position reference value during the whole motor displacement.

## 2 – USE OF THE SERIAL LINK

### 2.1 – OVERVIEW

Specifications of the serial link:

- 8 data bits, 1 stop bit, no parity,
- 19200 baud.

The parameters can be sent to the amplifier by an ASCII terminal using the instructions list given in this section. Each instruction is coded as 2 ASCII characters with or without parameter.

Each instruction, which can be followed by one or two parameters sent to the amplifier, must end with a "carriage return" character (ASCII code 13). The parameters must be separated by a ',' (ASCII code 44).

All these characters, except for the "carriage return", will be sent back by the amplifier (echo).

The amplifier answer starts with a separation character ":" (ASCII code 58) possibly followed by a value. The amplifier will then send a "carriage return", a "line feed" (ASCII code 10) and ">" (ASCII code 62).

These instructions allow modifying or to read the value of a variable. If there is a parameter, the variable corresponding to the instruction will take this value. Otherwise, the amplifier will send back the actual variable value.

#### Notes :

- If the amplifier does not know the instruction, it will send back "?" instead of ":".
- Some instructions are only valid when the amplifier is disabled.
- If the entered parameter is out of the appropriate variable range or if the restrictive condition (amplifier disabled) is not answered, the parameter will not be taken into account (the amplifier will keep the former variable value).
- The amplifier must work in hexadecimal mode for communicating with the ASCII terminal: VT-100 stand-alone mode must not be selected.



Dialog examples:

The user sends the NP instruction (number of motor pole pairs):

**NP4**

and a « carriage return » character for ending the instruction.

The amplifier will answer with:

**NP4:**

>

"NP4" is the echo of the characters sent. ":" indicates that the instruction has been decoded. The value 4 is stored in the variable corresponding to the number of motor pole pairs. After the "carriage return" character, the amplifier will also send the ">" character in order to indicate that it is ready for a new instruction.

If the user sends the instruction:

**NP,**

the amplifier will answer with:

**NP:4**

>

As there is no parameter in the instruction, the amplifier sends back the actual number of pole pairs.

## 2.2 - INSTRUCTIONS LIST

### Modify position of a sequence

*Instruction* YP

*Parameters* 1st parameter: sequence number.  
2nd parameter: position value.  
If there is no 2nd parameter, the amplifier will return the actual position value of the sequence (1st parameter).

*Conditions* This instruction can be sent only if there is no sequence executed.  
The sequence must exist.

*Unit* The unit of the position value is defined by "position resolution" and "decimal number" parameter values for the display in the PC software. However, via the ascii instruction, the position value must be sent without the decimal point.

Example :           position resolution : 5000  
                  decimal number : 3  
                  unit : mm

If the user wants to set a value 100 mm to sequence 3, the instruction will be:  
YP3,100000 (in decimal mode)

*Remark* The parameter modification takes effect immediately, but the parameter value is modified in the drive RAM memory only. A WR80 command must be executed if the modification must be saved into the drive EEPROM.

### Modify speed of a sequence

*Instruction* YS

*Parameters* 1st parameter: sequence number.  
2nd parameter: speed.  
If there is no 2nd parameter, the amplifier will return the actual speed of the sequence (1st parameter).

*Conditions* This instruction can be sent only if no sequence is executed.  
The sequence must exist.

The minimum speed is 2 rpm.

*Unit* rpm

*Remark* The parameter modification takes effect immediately, but the parameter value is modified in the drive RAM memory only. A WR80 command must be executed if the modification must be saved into the drive EEPROM.

### Modify acceleration of a sequence

<i>Instruction</i>	YA
<i>Parameters</i>	1st parameter: sequence number. 2nd parameter: acceleration time. If there is no 2nd parameter, the amplifier will return the actual acceleration time of the sequence (1st parameter).
<i>Conditions</i>	This instruction can be sent only if no sequence is executed. The sequence must exist.
<i>Unit</i>	Millisecond
<i>Range</i>	16 ms - 16000 ms
<i>Note</i>	The parameters <b>acceleration time</b> and <b>deceleration time</b> define the time with regard to the maximum speed parameter value. When the motion speed is lower than the maximum speed, the trajectory acceleration and deceleration times are proportionally reduced.
<i>Remark</i>	The parameter modification takes effect immediately, but the parameter value is modified in the drive RAM memory only. A WR80 command must be executed if the modification must be saved into the drive EEPROM.

### Modify deceleration of a sequence

<i>Instruction</i>	YD
<i>Parameters</i>	1st parameter: sequence number. 2nd parameter: deceleration time. If there is no 2nd parameter, the amplifier will return the actual deceleration time of the sequence (1st parameter).
<i>Conditions</i>	This instruction can be sent only if no sequence is executed. The sequence must exist.
<i>Unit</i>	Millisecond
<i>Range</i>	16 ms - 16000 ms
<i>Note</i>	The parameters <b>acceleration time</b> and <b>deceleration time</b> define the time with regard to the maximum speed parameter value. When the motion speed is lower than the maximum speed, the trajectory acceleration and deceleration times are proportionally reduced.
<i>Remark</i>	The parameter modification takes effect immediately, but the parameter value is modified in the drive RAM memory only. A WR80 command must be executed if the modification must be saved into the drive EEPROM.

### Sequences saving into the drive

<i>Instruction</i>	WR
<i>Parameters</i>	0x80.
<i>Conditions</i>	Amplifier disabled.
<i>Note</i>	The full sequences writing into the EEPROM takes many seconds. Wait for the drive reply before writing other parameters. If the saving operation is aborted, the drive will indicate an EEPROM fault at its next 24 V powering.

### Execution of a sequence

<i>Instruction</i>	GO
<i>Parameters</i>	1st parameter : sequence number.
<i>Conditions</i>	This instruction can be sent only if no sequence is executed. "Enable" signal is activated. "Stop" inputs are not activated. The sequence must exist.
<i>Note</i>	This instruction executes a sequence (with parameter as sequence number) regardless of the logic inputs status.

### Position feedback

<i>Instruction</i>	PF
<i>Parameters</i>	none
<i>Conditions</i>	Read only
<i>Note</i>	This instruction reads the motor position.
<i>Unit</i>	See " <i>modify position of a sequence</i> ".

### Inputs/Outputs status

<i>Instruction</i>	IO
<i>Parameters</i>	None
<i>Conditions</i>	Read only
<i>Notes</i>	This instruction reads the logic inputs and outputs status

<u>bit</u>	<u>meaning</u>
0	START
1	STOP
8	SEQ
9	POS
10	SPEED
16	IN1
17	IN2
18	IN3
19	IN4
20	IN5
21	IN6
22	IN7
23	IN8
24	OUT1
25	OUT2
26	OUT3
27	OUT4
28	OUT5
29	OUT6
30	OUT7
31	OUT8

- Bit SEQ indicates that the positioner is running a sequence.

- A sequence can be executed when bit STOP is not activated (equal to 0), and also if the security of the first sequence (HOME) is disabled.

### Absolute move

<i>Instruction</i>	MP
<i>Parameters</i>	absolute position
<i>Conditions</i>	"Enable" and "Run" signals are activated.
<i>Note</i>	
<i>Unit</i>	See " <i>modify position of a sequence</i> ".

### Speed (absolute move)

<i>Instruction</i>	DS
	Defines the speed for an absolute movement (MP).
<i>Parameters</i>	Speed
<i>Conditions</i>	
<i>Note</i>	This parameter is saved in the positioner memory. When the maximum speed parameter value is changed, this parameter value is scaled accordingly.
<i>Unit</i>	rpm

### Acceleration (absolute move)

<i>Instruction</i>	DA
	defines the acceleration for an absolute movement (MP).
<i>Parameters</i>	acceleration time
<i>Conditions</i>	
<i>Note</i>	The parameters <b>acceleration time</b> and <b>deceleration time</b> define the time with regard to the maximum speed parameter value. When the motion speed is lower than the maximum speed, the trajectory acceleration and deceleration times are proportionally reduced.
	This parameter is saved in the positioner memory.
<i>Unit</i>	Millisecond

**Deceleration (absolute move)**

<i>Instruction</i>	DD defines the deceleration for absolute movement (MP).
<i>Parameters</i>	Deceleration time
<i>Conditions</i>	
<i>Note</i>	The parameters acceleration time and deceleration time define the time with regard to the maximum speed parameter value. When the motion speed is lower than the maximum speed, the trajectory acceleration and deceleration times are proportionally reduced. This parameter is saved in the positioner memory.
<i>Unit</i>	Millisecond

**Stop**

<i>Instruction</i>	SOFF
<i>Parameters</i>	
<i>Conditions</i>	
<i>Remark</i>	Stops all movements except for jog.
<i>Note</i>	

**Software Enable**

<i>Instruction</i>	MA
<i>Parameter</i>	No parameter.
<i>Condition</i>	ENABLE input activated and positioner in local mode (Profibus operation mode selected and Profibus control deactivated).
<i>Note</i>	This command is not operating in the Stand-alone operation mode

**Software Disable**

<i>Instruction</i>	AR
<i>Parameter</i>	No parameter.
<i>Condition</i>	Positioner in local mode (Profibus operation mode selected and Profibus control deactivated).
<i>Note</i>	This command is not operating in the Stand-alone operation mode

**3 - USE OF THE VT 100 TERMINAL**

A VT-100 terminal can be connected to the serial link of the amplifier (X5 connector). The operator can use this terminal for displaying the axis position, for modifying or executing pre-programmed motion sequences, for moving the axis towards an absolute position or for controlling a JOG movement.

**3.1 - CONFIGURATION****3.1.1 – CONFIGURATION OF THE TERMINAL**

- Display over 4 lines of 20 characters each
- Serial link RS-232:
  - \* 19200 baud
  - \* 1 Stop bit
  - \* no parity
  - \* VT-100 protocol

**3.1.2 – CONFIGURATION OF THE POSITIONER**

The communication via the VT-100 terminal requires the amplifier to be configured at the hexadecimal address 7E by means of the DIP micro-switches.

## 3.2 – USE OF THE TERMINAL

### 3.2.1 – MAIN MENU

1	Display position
2	Modify sequence
3	Run sequence
4	Move_

In the main menu, keys 1, 2, 3 or 4 allow:

1. To display the motor position. The operator can then move the motor (Jog+ or Jog-) by means of the arrow keys.
2. To modify a given sequence:
  - \* Position modification of a given sequence: the operator enters the sequence number and the new position.
  - \* Speed modification of a given sequence: the operator enters the sequence number and the newly programmed speed.
3. To start a sequence: the operator enters the number of the sequence to be executed.
4. To move until a position: the operator enters the position and moves the motor until this position.

### 3.2.2 – POSITION DISPLAY

CD1-pm 103.000 mm
----------------------



The arrow keys allow moving the motor (Jog+ or Jog-), when the ENABLE signal is activated.

The  key allows the operator getting back to the main menu.

In this window, the operator can stop the motor (if it is rotary one) by pressing the  key.

STOP?_
--------

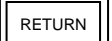
The operator must press the  key for confirming the motor stopping or any other key for cancelling.

### 3.2.3 – MODIFICATION OF A SEQUENCE

This menu allows the operator modifying position or speed of a given sequence.

```

MODIFY SEQUENCE
1   POSITION
2   SPEED
3   TORQUE_
  
```

The operator enters at first the sequence number (this sequence must exist).

```

MODIFY POS
Sequence:_
Pos:
Pos:
  
```

The former position is displayed and the operator can enter a new position or cancel by pressing the ENTER key.

```

MODIFY POS
Sequence: 1
Pos: 45.000
Pos:_
  
```

The operator can modify the speed or the torque of a given sequence in the same way:

```

MODIFY SPEED
Sequence: 1
Speed: 1000
Speed:_
  
```

```

MODIFY TORQUE
Sequence: 1
Torque: 10
Torque:_
  
```

The previous sequence modifications can be saved in the positioner memory as follows:

```

SAVE SEQUENCE
1: YES
2: NO_
  
```

### 3.2.4 – EXECUTION OF A SEQUENCE

When the positioner is not executing any sequence and when the ENABLE signal is activated, the operator can enter the number of a sequence to be executed:

```

RUN SEQUENCE
Sequence:_
  
```

### 3.2.5 - MOTION

When the positioner is not executing any sequence and when the ENABLE signal is activated, the operator can enter a position to be reached:

MOVEMENT POS : _
---------------------

### 3.3 – FAULT DISPLAY

Error code	Fault description
1	EEPROM parameters checksum
2	EEPROM sequences checksum
3	EEPROM sequences writing
4	Homing time out
5	EEPROM cogging checksum
6	EEPROM parameters writing
10	I <sup>2</sup> t
11	Position counting
12	Position following error
13	Bus error
14	Busy (procedure error)
20	Power overvoltage
21	24 Vdc out of range
22	Phase-earth short circuit
23	Braking resistor
24	Fan
25	Holding brake
28	Hall effect sensors / Com. channel
30	IGBT
32	Position sensor
33	Motor overtemperature
35	Power voltage initialisation (only for 400V range)
38	Current sensor offset
39	Overcurrent
40	Undervoltage
50	Non coded fault